



a Standex company

ITEM: _____ PROJECT NAME: _____ DATE: _____

SERIES '90 REFRIGERATED BAKERY CASE

MODEL SNR-48SC
 SNR-59SC
 SNR-77SC



Series '90. The ultimate merchandiser with advanced styling for maximum visual appeal. Cases are available in lengths of 48", 59", and 77". Designed for continuous case line-ups.

STANDARD FEATURES

- Adjustable white cantilevered wire shelves. Shelves are adjustable up and down, and can also be tilted.
- Lift-up pneumatic, cylinder-assisted, double-curve tempered front glass.
- Four-point leveling system.
- Removable sliding rear doors, shelf lights, shelf supports, and shelves.
- Glass ends and rear doors. Rear doors are sloped for product access.
- Octron top light and shelf lights. Lights are shielded and independently wired.
- All-welded base construction with a choice of six standard laminates on base. Other finishes optional.
- Easily accessible control panel with main power switch, light switch, digital thermometer, and adjustable temperature control.
- Base trim: specify white, black, or stainless.
- End glass trim: specify white or black.
- Double-bend tempered front glass reduces glare from outside lighting.
- Case height is only 48" high allowing better interaction between the customer and the sales clerk.
- White display deck.
- Condensate evaporator for a totally self-contained system.
- Average case temperature of 38° to 40°F is maintained without condensation on the front glass.
- Over-sized coil and low-velocity fan system maintains high humidity and product freshness.
- Pull-out condensing unit for quick and easy service.
- R134A Refrigerant.
- UL Safety and UL Sanitation Listed.

SERIES '90 REFRIGERATED BAKERY CASE

OPTIONAL ACCESSORIES:

- | | |
|---|---|
| <input type="checkbox"/> Special Base Finish | <input type="checkbox"/> Reflective End Glass |
| <input type="checkbox"/> Base Trim Specify White, Black, or Stainless | <input type="checkbox"/> Mirrored Interior Ends With Laminated Exterior |
| <input type="checkbox"/> End Glass Trim Specify White or Black | <input type="checkbox"/> Reflective Rear Doors |
| <input type="checkbox"/> Black or Stainless Steel Interior | <input type="checkbox"/> Chocolate Case Modification |
| <input type="checkbox"/> Glass, Black, or Chrome Shelves in Lieu of White | <input type="checkbox"/> Rear Wrapping Board |
| <input type="checkbox"/> LED or Promolux Lighting | <input type="checkbox"/> Front Glass and Rear Door Locks |
| <input type="checkbox"/> Casters or Legs | <input type="checkbox"/> Top Service Shelf (Stainless Steel or Glass) |
| <input type="checkbox"/> Cord and Plug (Six Foot) | <input type="checkbox"/> Remote Refrigeration |
| <input type="checkbox"/> Front Package Shelf With or Without Light Below | <input type="checkbox"/> Condensate Pump |

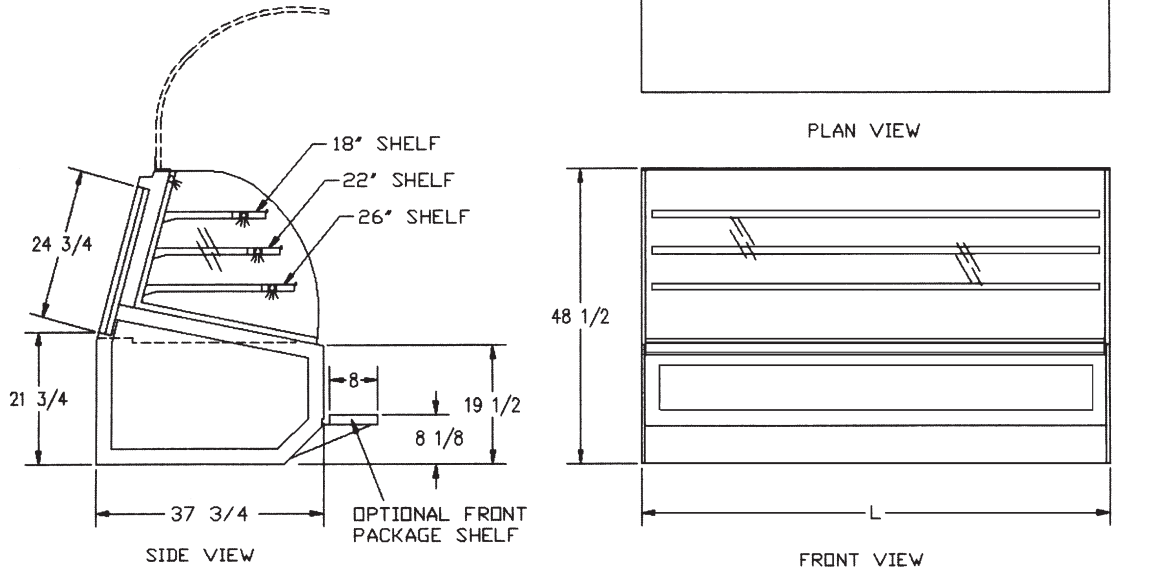

SPECIFICATIONS:

Model	Dimensions L W H	Shipping Weight (lbs)	Capacity (Bakery Pans)	Self-Contained 120/60/1	Remote 120/60/1
<input type="checkbox"/> SNR-48SC	48 1/4" x 37 3/4" x 48 1/2"	750	4 (18" x 26") 8 (12" x 18") 2 (9" x 26")	1/2 HP • 12 AMPS	13.2 AMPS
<input type="checkbox"/> SNR-59SC	59 1/4" x 37 3/4" x 48 1/2"	825	6 (18" x 26") 8 (12" x 18")	1/2 HP • 12 AMPS	13.2 AMPS
<input type="checkbox"/> SNR-77SC	77 1/4" x 37 3/4" x 48 1/2"	1,050	8 (18" x 26") 12 (12" x 18")	3/4 HP • 16 AMPS	17.3 AMPS

- Cases are designed to operate in a maximum environment of 75° ambient and 55% relative humidity.
- Due to continuing engineering improvements, specifications are subject to change without notice.



The Signature of Quality

FEDERAL INDUSTRIES
A Standex Company

215 FEDERAL AVENUE, BELLEVILLE, WISCONSIN 53508-9201
PHONE: 800-356-4206 **FAX: 608-424-3234**
EMAIL: geninfo@federalind.com **WEBSITE: www.federalind.com**

