



a Standex company

ITEM: _____ PROJECT NAME: _____ DATE: _____

**HIGH VOLUME
HOT DELI CASE
MODEL SG5048HD
SG5948HD
SG7748HD**



Display more product and serve more customers with presentation and value in mind. Cases are available in lengths of 50", 59", and 77". Designed for continuous case line-ups without middle end glass.

STANDARD FEATURES

- Designed for wet or dry heat.
- Sloped tempered tilt-out front glass for easy cleaning.
- Tempered glass top, ends, and doors.
- Stainless steel deck.
- Steel base construction with a choice of six standard laminates on base. Other finishes optional.
- Removable sliding rear doors with moisture vents. The moisture vents and a forced air front-glass defogger prevent excess moisture buildup.
- UL Safety and UL Sanitation Listed.
- Heating wells are one-piece stainless steel. Each well is heated with its own cal-rod heating element and is controlled by its own thermostat. Each well has a drain and valve.
- Top-mounted, full-length infrared heater provides uniform product temperature. Incandescent lighting provides even product illumination.
- Rear wrapping board.
- Each well holds a full-size pan.
- Black trim.
- Designed for continuous line-ups.

HIGH VOLUME HOT DELI CASE

OPTIONAL ACCESSORIES:

- Special Base Finish
- Reflective Ends
- White Ends or Mirrored Interior Ends with Laminated Exterior
- Reflective Rear Doors
- Legs
- Top Cutting Board, White
- Package Shelf
- Light Below Package Shelf
- Front Glass and Rear Door Locks
- Scale Platform
- Joining Kit for Continuous Line-ups

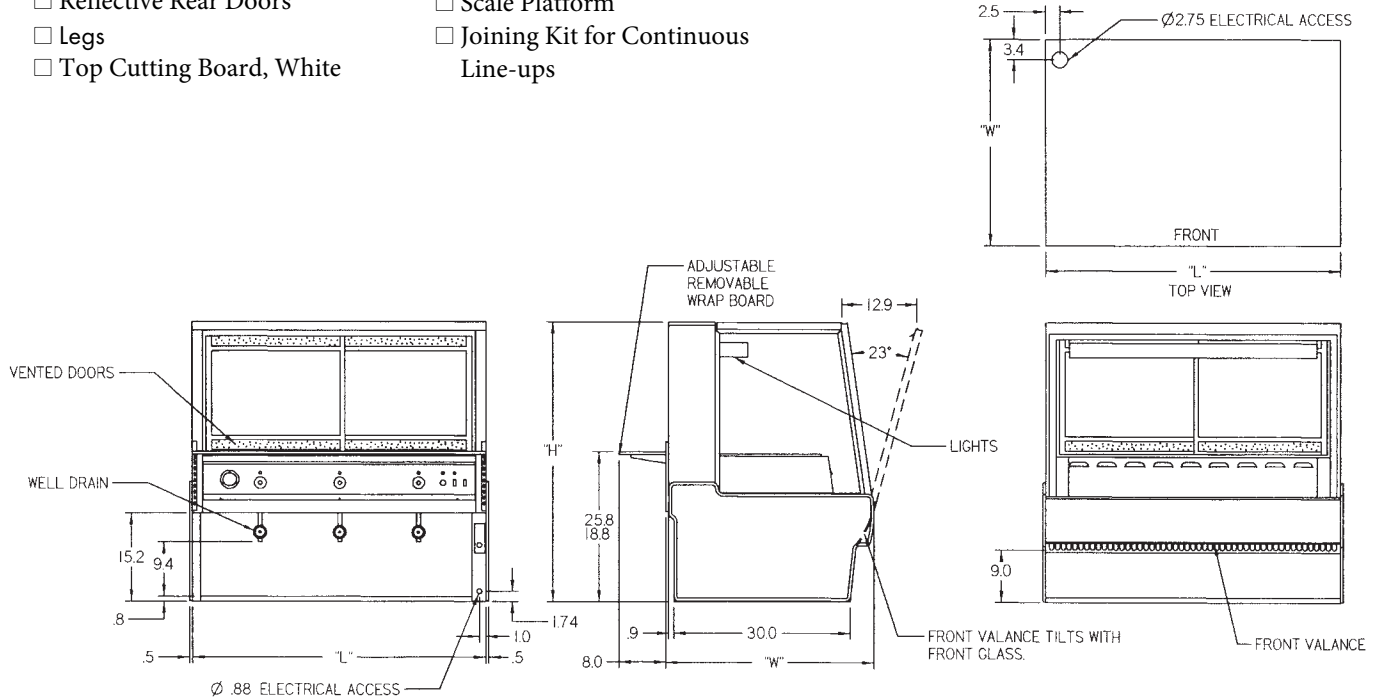

SPECIFICATIONS:

Model	Dimensions			Shipping Weight (lbs.)	Wells*	Electrical Requirements 120/208-240/60/1 3-Wire Plus Ground
	L	W	H			
SG5048HD	50.13"	35.31"	48"	535	3	19.6 AMPS
SG5948HD	59.13"	35.31"	48"	660	3	19.6 AMPS
SG7748HD	77.13"	35.31"	48"	800	5	32.3 AMPS

*Each well holds a full-size pan.

• Due to continuing engineering improvements, specifications are subject to change without notice.



Look to Federal for Innovative Merchandising



The Signature of Quality

FEDERAL INDUSTRIES
A Standex Company

215 FEDERAL AVENUE, BELLEVILLE, WISCONSIN 53508-9201

PHONE: 800-356-4206

EMAIL: geninfo@federalind.com

FAX: 608-424-3234

WEBSITE: www.federalind.com

