

# Operations & Service Manual

WOG-20MP &  
WOG-20MP-VH



Model WOG-20MP



Model WOG-20MP-VH

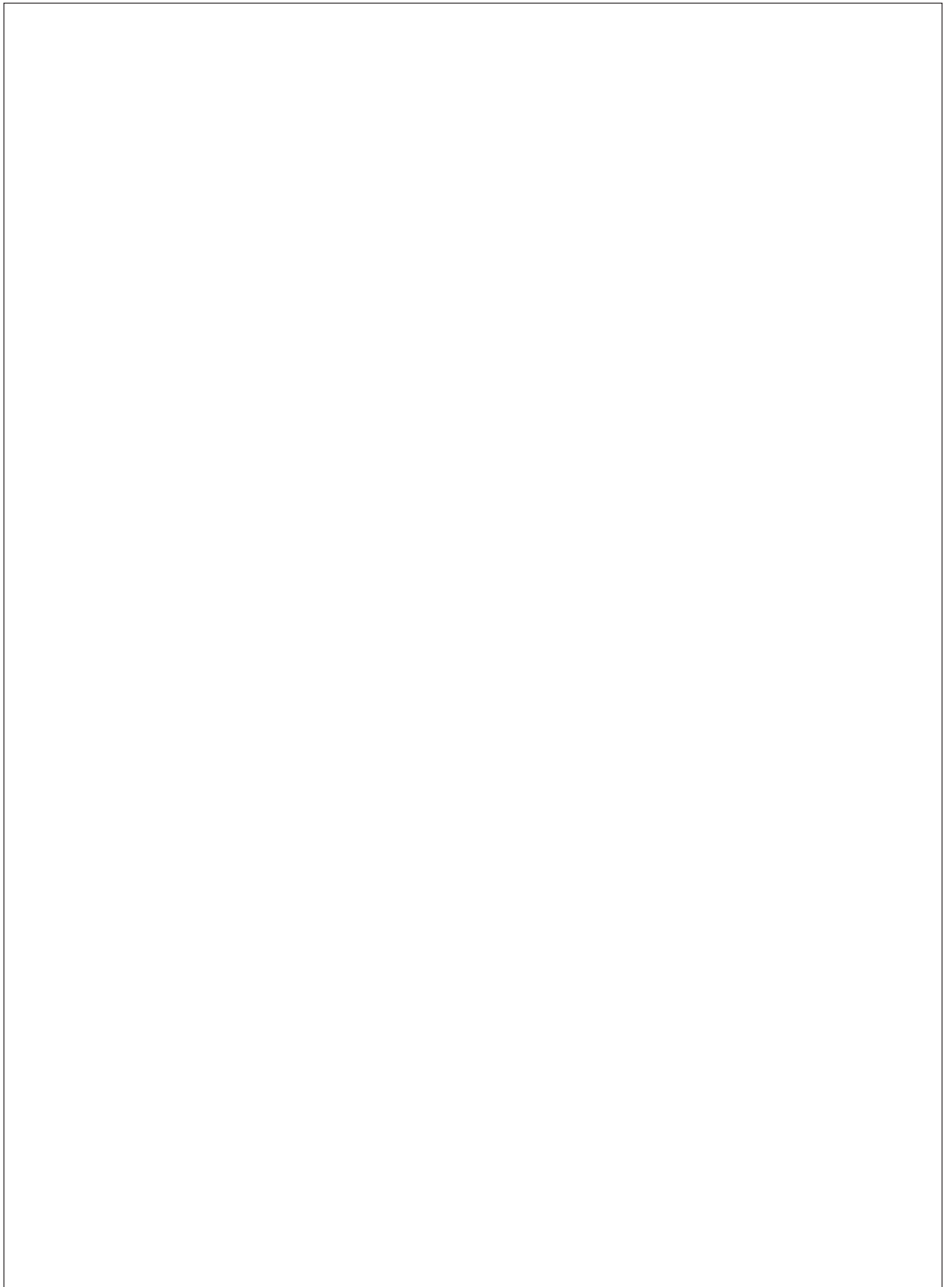

## LIMITED WARRANTY

- Subject to the terms and conditions of this Limited Warranty as herein stated, all Giles Enterprises, Inc. foodservice equipment and parts purchased new from an authorized Giles Enterprises, Inc., representative are warranted as to defects in material or workmanship for a period of 24 months from the date of installation, provided, however, that with regard to labor costs in connection with this warranty, see below. All installations must be made by a qualified installing agency in accordance with all applicable codes and/or regulations in the jurisdiction in which installed. Limited warranty coverage is extended to the original owner only and is void if the unit is resold.
- During the Limited Warranty period, Giles Enterprises, Inc. will replace or recondition, at its factory, any part or parts of this unit which Giles Enterprises, Inc. inspectors judge defective, provided the unit has been subjected to normal usage, properly installed, operated and serviced. This Limited Warranty does not cover cosmetic damage, and damage due to acts of God, accident, misuse, alteration, negligence, abuse of the Giles Foodservice Equipment or the use of unorthodox repair methods. All parts replaced under this Limited Warranty carry only the unexpired term of this Limited Warranty. Limited Warranty service may be furnished only by an authorized Giles Enterprises, Inc., representative.
- If Limited Warranty service is requested, Giles Enterprises, Inc., will send factory-authorized service representatives to repair, recondition, replace or inspect units of its manufacture with such labor being rendered without cost to owner for twenty-four (24) months from the date of installation. Otherwise, service, including labor and transportation charges or other expenses, in connection with the removal or installation of any part or parts supplied under this Limited Warranty, are specified on the original sales contract between the purchaser and the authorized Giles Enterprises, Inc., representative.
- **Failure to use Giles OEM parts and Giles OEM replacement filters may void the factory warranty.**
- Giles Enterprises, Inc. reserves the right to change or improve its equipment and parts in any way without obligation to alter such equipment or parts previously manufactured.
- Giles Enterprises, Inc. makes no further warranties, express or implied including implied warranties of merchantability or fitness for a particular purpose, and has no other obligation or liability not specifically stated herein.
- Repair or replacement as provided under this limited warranty is the exclusive remedy. Giles Enterprises, Inc., shall not be liable for any incidental or consequential damages for breach of any express or implied warranty on this product, except to the extent prohibited by applicable law. Any implied warranty of merchantability or fitness for a particular purpose on this product is limited in duration to the duration of this limited warranty.
- Used Giles Enterprises, Inc., Foodservice Equipment or parts or Giles Enterprises, Inc., Foodservice Equipment or parts not purchased from an authorized Giles Enterprises, Inc., representative, carry no warranties, express or implied.



## Safety vii

Safety Overview . . . . . vii

Specific Safety Precautions . . . . . viii

## 1. Introduction . . . . . 1

1-01. Construction . . . . . 1

1-02. Standard Features . . . . . 1

1-03. Optional Ventless Hood Features . . . . . 1

1-04. Specifications . . . . . 2

1-04.01. Overall Dimensions for WOG-20MP . . . . . 2

1-04.02. Overall Dimensions for WOG-20MP-VH . . . . . 3

1-04.03. Regulatory Listings . . . . . 4

1-04.04. Basket Size (2 Baskets included) . . . . . 4

1-04.05. Cooking Capacity . . . . . 4

1-04.06. Unit Weights . . . . . 4

## 2. Installation . . . . . 5

2-01. Location . . . . . 5

2-02. Unpacking . . . . . 6

2-03. Electrical Requirements . . . . . 7

2-04. Electrical Connections . . . . . 7

2-04.01. Routing conduit . . . . . 8

2-05. Ventilation for Non-Ventless Fryer (WOG-20MP) . . . . . 9

2-06. Ventless Hood Clearances (WOG-20MP-VH) . . . . . 9

2-07. Ventless Hood Fire Suppression System (WOG-20MP-VH) . . . . . 9

2-08. Fusible Link and Gas Cartridge Locations (WOG-20MP-VH) . . . . . 9

2-09. Fire Extinguisher Nozzle and Tank Locations (WOG-20MP-VH) . . . . . 10

## 3. Overview . . . . . 11

3-01. Cooking Vat . . . . . 12

3-02. Control Panel . . . . . 14

3-03. Lower Cabinet Area . . . . . 16

3-04. Filter Pan Assembly . . . . . 18

3-05. Ventless Hood (VH) . . . . . 20

3-06. Accessories (Included) . . . . . 22

3-07. Accessories (Not Included) . . . . . 24

## 4. Unit Preparation . . . . . 27

4-01. Settings before testing unit . . . . . 27

4-02. Power Test . . . . . 28

4-03. Heating Element Test . . . . . 28

4-04. Filter Pump Test . . . . . 30

4-05. Perform Boil Out Procedure . . . . . 30

4-06. Initial Cleaning of the Appliance . . . . . 31

<b>5.</b>	<b>Fryer Operation</b>	<b>33</b>
5-01.	Cooking Control - Overview	35
5-01.01	Setting the Temperature Unit	36
5-01.02	Setting the Cooking Temperature	37
5-01.03	Setting a Cooking Time	38
5-02.	Cooking Procedure	39
5-03.	Filtering the Cooking Oil	43
5-04.	Removing Used Cooking Oil from Fryer	47
5-05.	Normal Shutdown	50
5-06.	Emergency Shutdown	50
<b>6.</b>	<b>Cleaning</b>	<b>53</b>
6-01.	Boil-Out Procedure (Cleaning the Cooking Vat)	53
6-02.	Cleaning the Filter Pan and Refreshing Filter Media Daily	56
6-03.	Cleaning the Filter Pan and Refreshing Filter Media after Boil-Out	57
<b>7.</b>	<b>Ventless Hood</b>	<b>59</b>
7-01.	Hood Operation	59
7-02.	Filters	59
7-02.01.	Ventless Hood Filter Table	59
7-02.02.	Baffle Filter Removal and Installation	60
7-02.03.	Electronic Air Cleaner (EAC) Cell Removal and Installation	61
7-02.04.	Charcoal Filter Removal and Installation	62
7-03.	Filter Alarms	63
7-03.01.	Baffle or Charcoal Filter Missing Alarm (constant tone)	63
7-03.02.	Electronic Air Cleaner (EAC) Alarm (beeping tone)	63
7-03.03.	Clogged Filter Alarm (constant tone)	64
7-04.	Filter Cleaning	64
7-04.01.	Cleaning the Baffle Filter	64
7-04.02.	Cleaning the EAC Filter Cell	65
7-04.03.	Charcoal Filter Replacement	66
7-05.	Ventless Hood Maintenance	66
7-05.01.	Monthly Interlock Inspection	66
7-05.02.	Quarterly Hood Cleaning	67
7-05.03.	Semi-Annual Fire Suppression System	67
7-05.04.	Annual Fire Suppression System	67
7-05.05.	12 Year Suppression System	67
7-05.067.	Maintenance and Service Log	68
<b>8.</b>	<b>Troubleshooting</b>	<b>69</b>
8-01.	Temperature Control System	69
8-02.	Oil Filtration System	72



<b>9.</b>	<b>Parts List</b> . . . . .	<b>71</b>
9-01.	Parts Ordering and Service Information . . . . .	71
9-02.	Control Panel . . . . .	72
9-03.	Front Header . . . . .	74
9-04.	Front Lower Cabinet . . . . .	76
9-05.	Rear Lower Cabinet . . . . .	78
9-06.	Rear Top Header/Cabinet (WOG-20MP) . . . . .	80
9-07.	Rear Component Assembly (WOG-20MP-VH) . . . . .	82
9-08.	Hood Cabinet Rear (WOG-20MP-VH Ventless Hood) . . . . .	84
9-09.	Cooking Vat . . . . .	86
9-10.	Front Ventless Hood (WOG-20MP-VH) . . . . .	88
9-11.	Filter Pan . . . . .	90

# Model: WOG-20MP & WOG-20MP-VH



## Safety

### Safety Overview

The instructions contained in this manual have been prepared to help ensure use of proper procedures when installing, operating, and servicing the **WOG-20MP or WOG-20MP-VH Fryer**.

Throughout this manual, safety precautions are identified by safety alert symbols and key words such as **DANGER**, **WARNING** and **CAUTION**. All safety alert information will precede the information to which it applies. Suggested, recommended, or otherwise noteworthy information is identified through the use of **NOTES or IMPORTANT!** comments. Additionally, certain words are used to indicate specific meaning, added emphasis.

The following words are used as indicated throughout the manual:

**Shall:** understood to be mandatory.

**Should:** understood to be advisory.

**May:** understood to be permissive.

**Will:** indicates a future event or condition is highly likely to occur.

#### Safety Alert Symbol

Used in conjunction with key words such as **DANGER**, **WARNING**, or **CAUTION** to alert the user to potential personal injury hazards, and to highlight precautionary measures that pertain to certain operational tasks. Adhere to all safety information following these symbols to avoid possible injury, or even death. Failure to comply with safety precautions identified by a safety alert symbol may also void the equipment's warranty.

#### **DANGER**

- Indicates an imminently hazardous situation which, if not avoided, will result in severe injury, or even death. Use of this is limited to the most extreme situations.

#### **WARNING**

- Indicates a potentially hazardous situation which, if not avoided, may result in serious injury, or even death.

#### **CAUTION**

- Indicates a potentially hazardous situation which, if not avoided, may result in minor to moderate injury. Also alerts against unsafe practices.

#### **CAUTION**

- When used without the safety alert symbol, **CAUTION** indicates a potentially hazardous situation which, if not avoided, may result in damage to the equipment or property, and void the warranty.

#### **NOTE or IMPORTANT!**

- Identifies suggested, recommended, or otherwise noteworthy information.

## Specific Safety Precautions

For your safety, please observe the following precautions when operating, or servicing, the WOG-20MP or WOG-20MP-VH Fryer. Adhere to the following important safety information to avoid personal injury and/or damage to the equipment or property.

### **DANGER**

- Turn the unit **OFF** and disconnect from power source before cleaning or performing maintenance.
- **DO NOT** washdown the interior or exterior of the appliance with water from a spray hose.
- Failure to comply with **DANGER** notices will result serious injury, even death; equipment and/or property damage; and will potentially void the factory warranty.

### **WARNING**

- Prior to installation, consult a qualified electrician to ensure that all electrical requirements and codes have been met.
- **The unit must be adequately and properly grounded. Improper grounding may result in electrical shock. Always refer to local electrical code to ensure proper grounding of this or any other electrical equipment. Always consult with an electrician or other qualified service technician to ensure that circuit breakers and wiring are of sufficient rating and gauge to power this equipment. A Wiring Diagram has been provided with the unit as an aid for electricians and technicians. The unit must be installed and electrically grounded in accordance with local codes, or in the absence of local codes, in accordance with the National Electrical Code, NFPA 70.**
- Improper installation, adjustment, alteration, service or maintenance could in serious injury, even death; equipment and/or property damage; and will potentially void the factory warranty.
- **DO NOT** use or store flammable liquids, or materials that produce flammable vapors, in the vicinity of this or any other appliance!
- Failure to comply with **WARNING** notices could result in serious injury, even death; equipment and/or property damage; and will potentially void the factory warranty.

### **CAUTION**

- The WOG-20MP and WOG-20MP-VH must remain in an upright (vertical) position.
- Exercise care when removing the wooden crate framework, and the unit from the shipping pallet.
- **DO NOT** operate the appliance unless you fully understand the components and controls, and their intended function (see Section 3).
- This appliance is not intended for use by persons (including children) with reduced physical, sensory, or mental capabilities, or lack of experience and knowledge, unless they have been given adequate instruction and/or supervision concerning its use by a person responsible for their safety.
- Failure to comply with **CAUTION** notices may result in minor or moderate injury, equipment and/or property damage, and will potentially void the factory warranty.

## CAUTION

- Children should be supervised, or otherwise restricted, to ensure they do not play with or around this appliance.
- After cooking and prior to sale, food products must be maintained at a temperature of 150°F (65.5°C) minimum, or in accordance with governmental health regulations.
- Units are available from the factory wired for various voltages, phases and hertz. Check the rating label on the front, or rear, of the unit to determine the proper power supply required.
- Ensure the unit is positioned in a secure, stable location. When in use always ensure that the caster brakes are locked.
- Due to the high temperature of the cooking oil during operation, it is extremely important that the user exercise caution when working with the appliance to avoid personal injury.
- Before attempting to operate the unit, refer to **Section 3** to familiarize yourself with the various control functions. Once you have read and fully understand that Section, please follow the procedures in this Manual precisely, to prevent equipment damage or malfunction.
- Allow the appliance to cool down a minimum of 15-20 minutes before cleaning or servicing.
- **DO NOT** bend the collection fins or break the ionizer wires of the Electronic Air Cleaner (EAC) cell. Doing so will prevent it from working properly and may cause power to the heating element to be shutdown. (WOG-20MP-VH only)
- After cleaning the EAC cell, **DO NOT** attempt to dry it by installing it in the Fryer Hood and running the fan to force air dry it, or by heating the Fryer to heat dry it. This could potentially damage the EAC power supply and control system, leading to malfunction and voiding the warranty. The EAC filter must air dry at ambient room temperature, preferably overnight. (WOG-20MP-VH only)
- The WOG-20MP and WOG-20MP-VH and its parts will become **HOT!** Temperatures inside the Cabinet may exceed 150°F (65.5°C). Exercise caution when operating, loading or unloading food items, cleaning or servicing. Wearing personal protective equipment (PPE), such as thermal oven mitts is recommended.
- Failure to comply with **CAUTION** notices may result in minor or moderate injury, equipment and/or property damage, and void the warranty.

## CAUTION

- The Control Panel components are somewhat impact sensitive. Exercise care when working with items, such as carts or baskets, near the front of the Fryer to avoid possible damage and maintain proper operation.
- **DO NOT** install the unit next to combustible walls and materials. Failure to maintain safe distances may result in fire.
- When cleaning the appliance:
  - **DO NOT** steam clean.
  - **DO NOT** use products containing chlorine, or other caustic chemicals.
  - **DO NOT** use abrasive products, steel wool or scouring pads.
  - **DO NOT** use oven cleaners.
- **DO NOT** alter, add attachments, or otherwise modify this equipment!
- Failure to comply with these **CAUTION** notices may result in equipment and/or property damage, and will potentially void the factory warranty.

## IMPORTANT!

- Upon delivery, the palletized unit should have been thoroughly inspected. If damage is evident, the shipment should have been refused and damages promptly reported to the freight company. **It is generally the customer's responsibility to negotiate freight damage claims.**
- As an aid for electricians and installers, an electrical wiring diagram is provided with the unit. Refer to the wiring diagram during installation or while servicing.
- Comply with all appropriate governmental health regulations regarding cleaning and sanitation of foodservice equipment.
- Giles recommends the use of mild, bio-degradable, non-toxic degreasers, such as **Clear Magic** or **Simple Green**, for cleaning parts of the Fryer and Hood where excessive grease film accumulation is present.
- Never attempt to clean and reuse the Charcoal Filter (WOG-20MP-VH only).
- The appliance and plenum nozzles have been factory installed and aligned in the proper operating position. **DO NOT MOVE OR ADJUST THESE NOZZLES** (WOG-20MP-VH only).
- The sound level of the hood while operating is approximately 65 dB (WOG-20MP-VH only).
- **For some installations, it may be necessary to consult a HVAC specialist to confirm that proper room air exchange is occurring and that the on-site air conditioning system is capable of handling anticipated heat load.**
- Exhaust ventilation is recommended for areas in which recirculating hoods are operated. Giles recommends **50 CFM** per linear foot of hood space. **This amount could vary based on local codes and site-specific situations.** (WOG-20MP-VH only)

## 1. Introduction

Thank you for purchasing this new Giles Foodservice Fryer, Model WOG-20MP or WOG-20MP-VH, manufactured by Giles Enterprises, Inc., Montgomery, Alabama (USA), hereafter referred to as "Giles". Every unit is thoroughly inspected and tested prior to shipment. Proper care and maintenance will ensure years of trouble-free service.

To help protect your investment, we recommend that you take a few moments to familiarize yourself with the installation, operational, cleaning, and maintenance procedures contained in this Manual. Adherence to these recommended procedures minimizes the potential for costly "downtime" and future equipment repairs. Please retain this Manual for later reference.

### 1-01. Construction

This appliance is constructed of various guage Series 430 stainless steel sheet metal.

### 1-02. Standard Features

**Digital Temperature Control:** User-friendly thermostat controls cooking oil temperature, adjustable up to 375°F (191°C).

**Mechanical Cooking Timer:** Adjustable from 0 to 30 minutes, sounds alarm at end of the set cooking time.

**Oil Filtration System:** Built-in automatic oil filtering system with high capacity pump. Can extend life of cooking oil by as much as 50%.

**Ventless Unit Only (WOG-20MP-VH) ...**

**Ventless Hood:** Integral recirculating Hood system removes the grease-laden vapor generated during cooking from the air without the need for venting to the outside.

**Extinguishing System:** Built-in Ansul® R-102 fire extinguishing system to suppress any accidental cooking oil fire.

### 1-03. Optional Features

**Interlock Start (ILS) WOG-20MP-VH ONLY:** "Push to Start" feature will not allow the Appliance to restart after a power interruption until it is attended by the user. This system is required by some state and/or city authorities. Consult with local code officials to determine if this is a requirement.

## 1-04. Specifications

### 1-04.01. Overall Dimensions for WOG-20MP

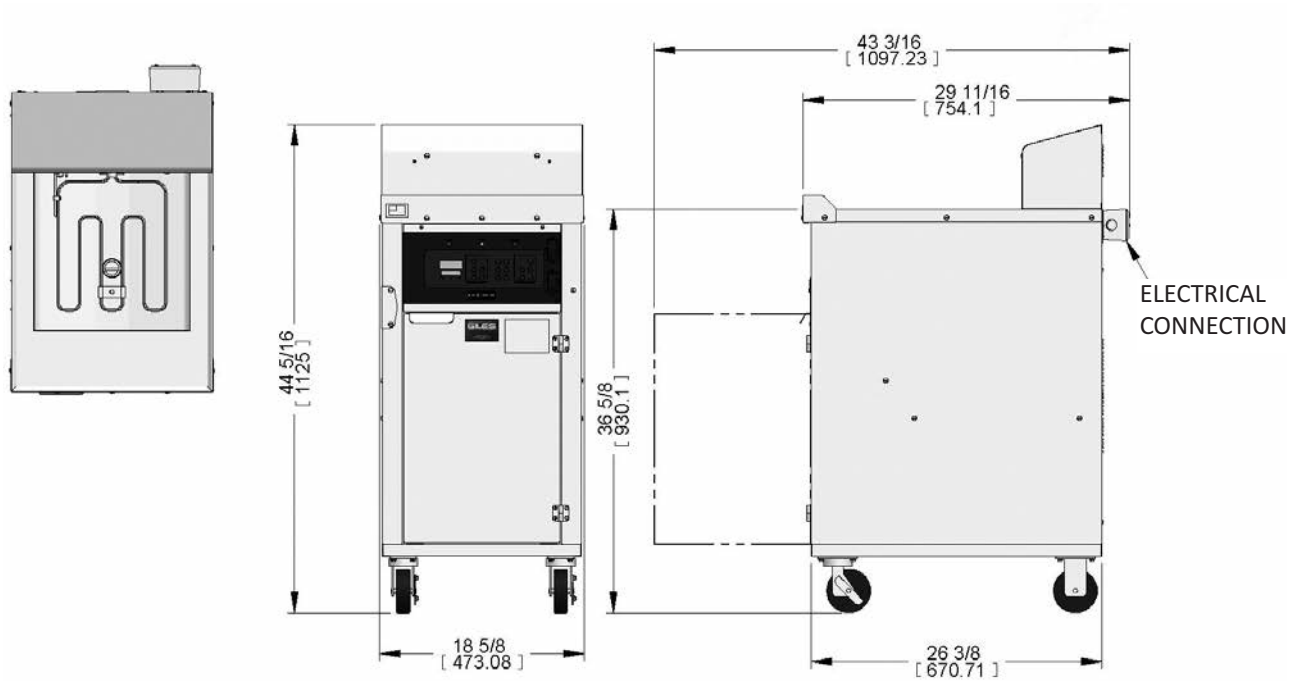

INCHES [mm]

## 1-04.02. Overall Dimensions for WOG-20MP-VH

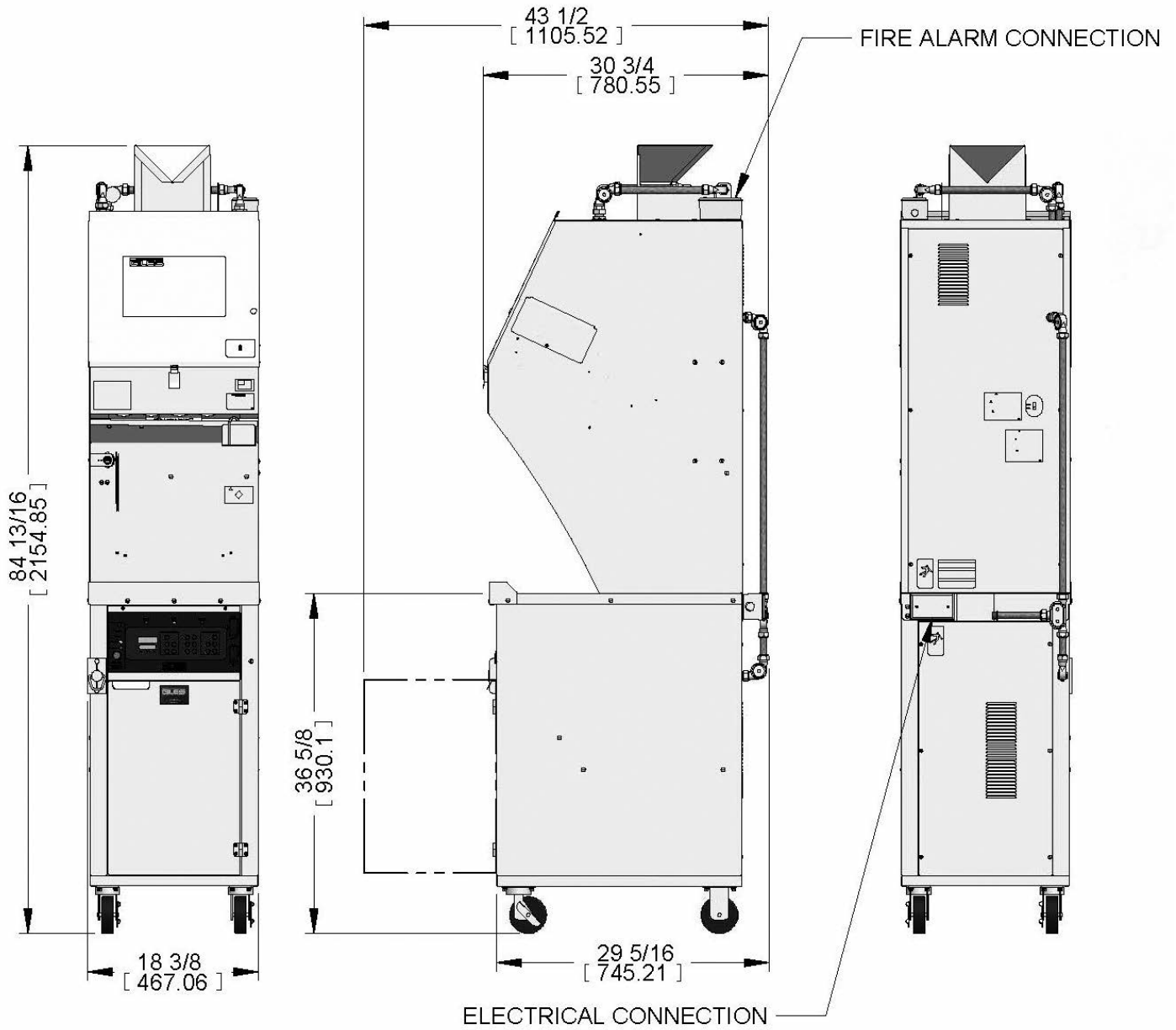

INCHES [mm]

**1-04.03. Regulatory Listings**



**1.04.04. Baskets (2 included)**

Basket Size						Volume	
Length		Width		Height		Cubic in	Cubic m
in	mm	in	mm	in	mm		
10.125	257.1	4.438	112.7	4.375	111.1	196.58	0.003

**1-04.05. Cooking Capacity**

Liquid Shortening Capacity			
Lb	Kg	Gal	Liter
34-3/4	15.8	4.5	17.0

Production capacity reference: 3 lbs of French Fries per 5 minutes.

**1-04.06. Unit Weights**

Model	Crated		Uncrated	
	Lb	Kg	Lb	Kg
WOG-20MP	283	128	212	96
WOG-20MP-VH	455	206	319	145

## 2. Installation

The following section provides a summary of the procedures necessary for proper installation of the Model WOG-20MP or WOG-20MP-VH. To prevent personal injury or equipment damage, please follow these steps accordingly.

### 2-01. Location

**NOTE:**

When operating, the decibel level of the hood on the WOG-20MP-VH Ventless Fryer is approximately 65 dB.



**DO NOT ALTER, ADD ATTACHMENTS, OR OTHERWISE MODIFY THIS EQUIPMENT.**

1. Keep the appliance and surrounding area free and clear from combustible materials. Maintain 3" (7.6cm) clearance to the appliance.
2. Be sure the unit is electrically grounded in accordance with local codes, or in the absence of local codes, with the National Electrical Code, NFPA 70.
3. Please provide adequate room for servicing and proper operation of this appliance. Also, provide adequate ventilation in the operating area where necessary.
4. Always consult an electrician or other qualified individual prior to installation.
5. Be sure that the circuit intended to supply power to the unit complies with the appliance's electrical specification (voltage/amperage) as stated on the rating label.
6. Place unit in a stable position and ensure it cannot be unintentionally moved. Locking casters are supplied on this appliance and must be placed in the locked position when operating.
7. Depending on local code, room size and other appliances in use, exhaust ventilation may be required when operating the WOG-20MP-VH. This often can be accomplished by the installation of an exhaust fan in the room in which the appliance is installed. To determine the requirements for your installation, supply the HVAC dealer the following information.
  - a. The WOG-20MP-VH exhausts 267 to 382 CFM.
  - b. The average temperature of the air being exhausted from the Hood, after four (4) hours of continuous frying, will be approximately 90°F (32°C).
8. This appliance is to be installed, used and maintained in accordance with the **Standard for Ventilation Control and Fire Protection of Commercial Cooking Operations, NFPA 96.**

Adherence to the above steps will help ensure safe and proper installation of the appliance. If you have any questions concerning the installation, contact a nearby Giles Manufacture's Representative, or call Giles at **800.554.4537** for further assistance.

## 2-02. Unpacking

The unit will arrive enclosed by a wooden framework, secured to a wooden shipping pallet by means of high-tensile strength strapping. The load is wrapped in machine-applied shrink wrap.

### CAUTION

- The appliance must remain in an upright (vertical) position.
- Exercise care when lifting or moving the unit.
- Exercise care when removing the wooden framework from around the unit.
- Failure to comply with these **CAUTION** notices may result in minor or moderate injury, equipment/property damage, and void the warranty.

### NOTE:

If the palletized load shows evidence of damage, immediately inspect the unit and any packed accessories, and notify the freight carrier. **Typically, it will be the customer's responsibility to negotiate freight damage claims.**

1. Carefully cut and remove the plastic shipping wrap and the strapping.
2. Use appropriate tools to remove the wooden framework from around the unit.
3. Using sufficient assistance, or appropriate equipment, carefully remove the unit from the shipping skid. The appliance is very heavy, see **Weights, Section 1-03.06**, great care should be taken when lifting or moving the unit to prevent personal injury or equipment damage.
4. Remove and set aside all accessory items that are packed with the unit.

### NOTE FOR VH MODELS:

- **A HVAC specialist may be required for some installations to confirm proper room air exchange and the heat load capabilities of the on site air conditioning system.**
- Exhaust ventilation is recommended for areas in which recirculating hoods are used. Giles recommends 50 CFM per lineal foot of hood space.
- This amount could vary based on local codes and site specific installation requirements.

## 2-03. Electrical Requirements

### CAUTION

- The unit must be adequately and properly grounded. Improper grounding may result in electrical shock. Always refer to local electrical code for proper grounding procedures of this, or any other electrical equipment. Always consult with an electrician, or other qualified service person, to ensure that breakers and wiring supplying power to the appliance are of sufficient rating and gauge for the load.
- Units are available from the factory with any of the electrical specifications listed below. Check the rating label on the rear of the unit to determine the correct power supply.

Recommend Circuit Breaker					
Model	Voltage	Phase	Hz	Amps	Breaker Size
WOG-20MP	208	1	60	29	40
WOG-20MP	240	1	60	25	40
WOG-20MP	220	1	50	27	40
WOG-20MP	230	1	50	26	40
WOG-20MP-VH	208	1	60	29	40
WOG-20MP-VH	240	1	60	25	40
WOG-20MP-VH	220	1	50	27	40

## 2-04. Electrical Connections

### Power Connection

1. Install appropriate circuit breaker in the Main Panel; see **Table 2-03**.
2. Connect appropriately sized flexible conduit from Main Breaker Panel to the appliance. Allow enough conduit so the unit can be sufficiently moved for cleaning and servicing; see **Figure 2-04.1**.
3. Remove cover from the appliance's Service Box; see **Figure 2-04.1**.
4. Route appropriately size wire from the Breaker Panel to the unit.
5. Connect the incoming power wires to the appliance's power lead wires, located in the Service Box, using appropriate size wire nuts.
6. Reinstall Service Box Cover.

Continued next page 

## 2-04. Electrical Connections (Continued from previous page)

### Fire Alarm Connection (WOG-20MP-VH Ventless Model Only):

If the appliance's Fire Extinguisher System has been activated, this connection sends a signal to the building fire alarm system.

1. Remove Cover on Fire Alarm Tie-In Box and run appropriate size conduit and wire from the Box to the building's Fire Alarm System control panel. Allow enough conduit and wire so that the appliance can be accessed for cleaning and servicing.
2. Make appropriate connections.
3. Reinstall Fire Alarm Tie-In Box Cover.

### 2-04.01. Conduit Routing

#### NOTE:

Electrical installation labor and materials (conduit, wire, connectors, etc.) required to install the appliance shall be provided by the customer.

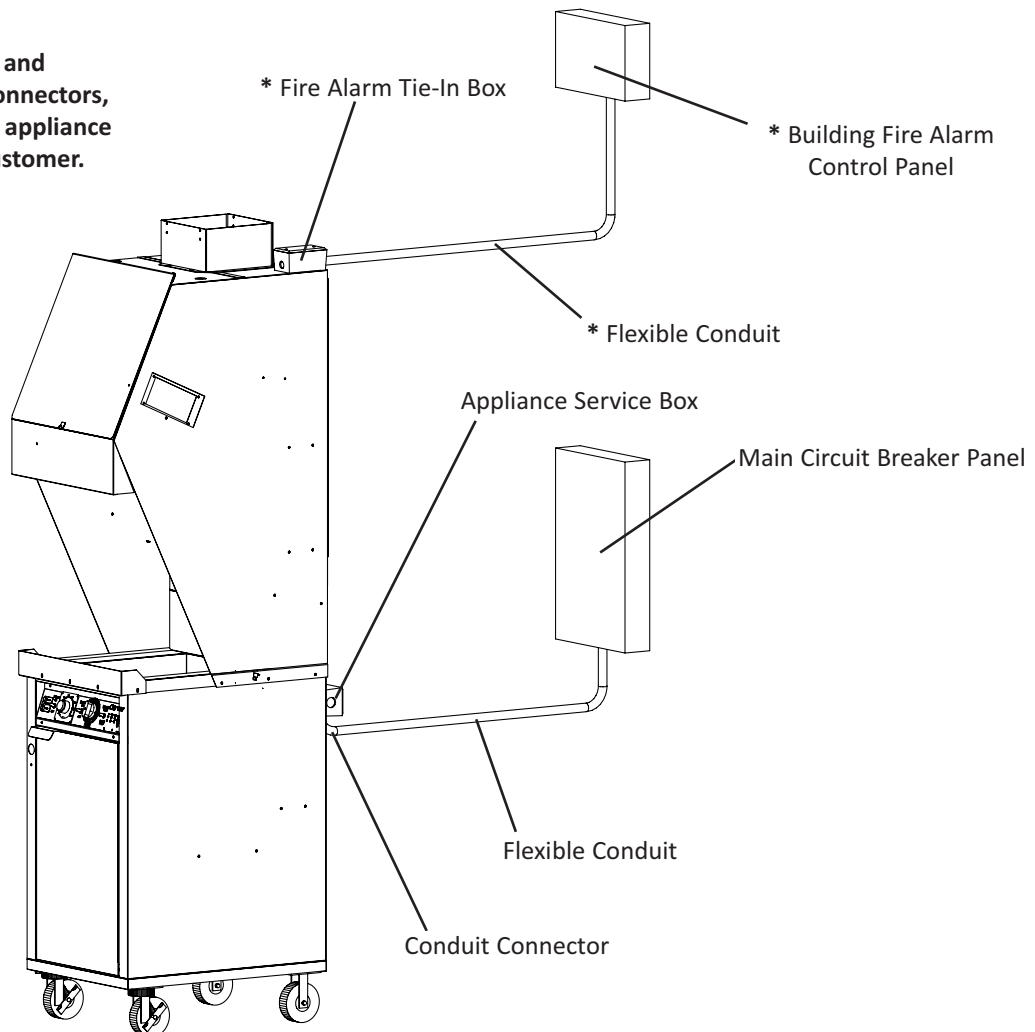

\* Ventless Hood Model Only

## 2-05. Ventilation for Non-Ventless Fryer (WOG-20MP)

**NOTE:**

Guidelines for proper ventilation requirements may differ from location to location. Always consult with local authorities to ensure compliance with current codes.

Consult a professional ventilation, or HVAC company, for assistance in designing a hood system for the WOG-20MP.

## 2-06. Ventless Hood Clearances (WOG-20MP-VH)

The WOG-20MP-VH is equipped with a 3-way exhaust Air Diverter. There is no minimum clearance requirement from the top of the Diverter to the ceiling, however it is recommended that sufficient clearance be allowed to facilitate ease of movement or relocation of the appliance should the need arise.

## 2-07. Ventless Hood Fire Suppression System (WOG-20MP-VH)

The fire suppression system in the WOG-20MP-VH Ventless Hood section is an Ansul® R-102 Restaurant Fire Suppression System (UL197 Listed). **Final installation, charging and testing of the system shall be performed by an authorized Ansul distributor in accordance with the system's listing. The expense for this work is not included with purchase, and shall be the responsibility of the customer.**

The fire suppression system is designed and UL-listed to provide fire protection for the appliance. It automatically provides full-time fire protection. The system includes factory installed piping, discharge nozzles (appliance and plenum), fusible link brackets, conduit and 1.5 gal. stainless steel, wet chemical, suppressant tank.

## 2-08. Fusible Link and Gas Cartridge Locations (WOG-20MP-VH)

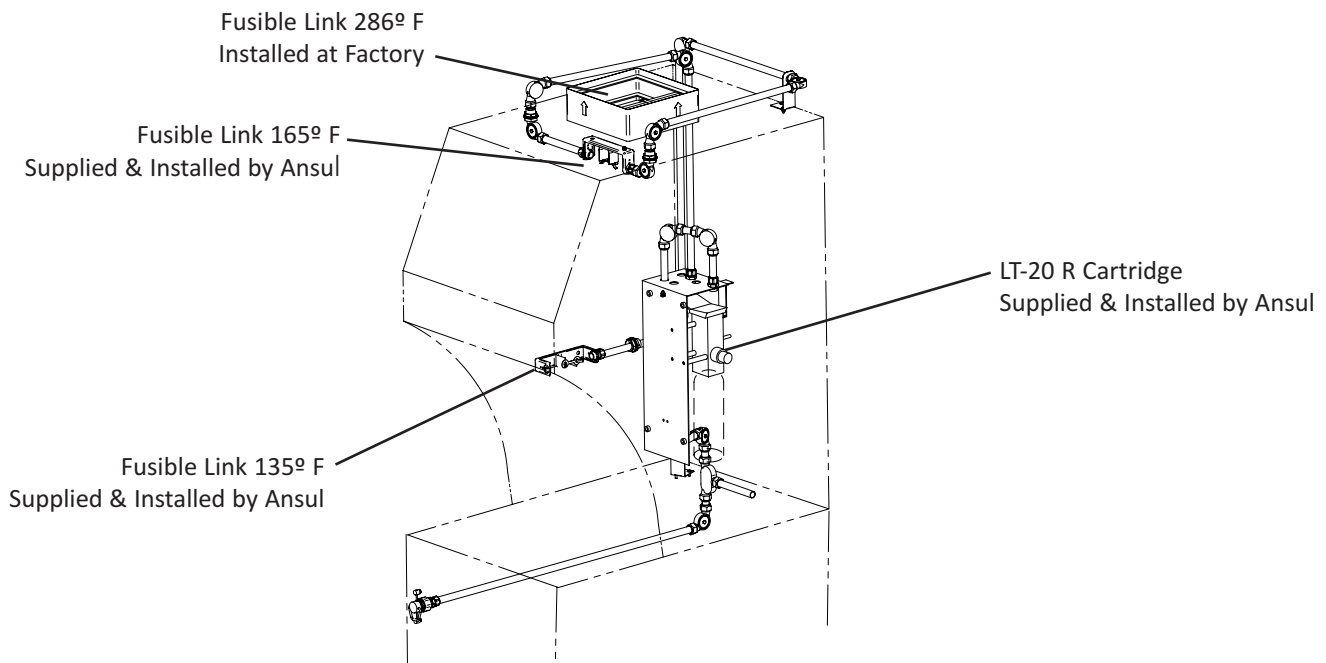

## 2-09. Fire Extinguisher Nozzle and Tank Locations (WOG-20MP-VH)

All nozzles have been factory installed and aligned in the proper operating position. **DO NOT MOVE OR ADJUST. SHOULD ONLY BE ADJUSTED BY A QUALIFIED FIRE PROTECTION COMPANY AGENT.**

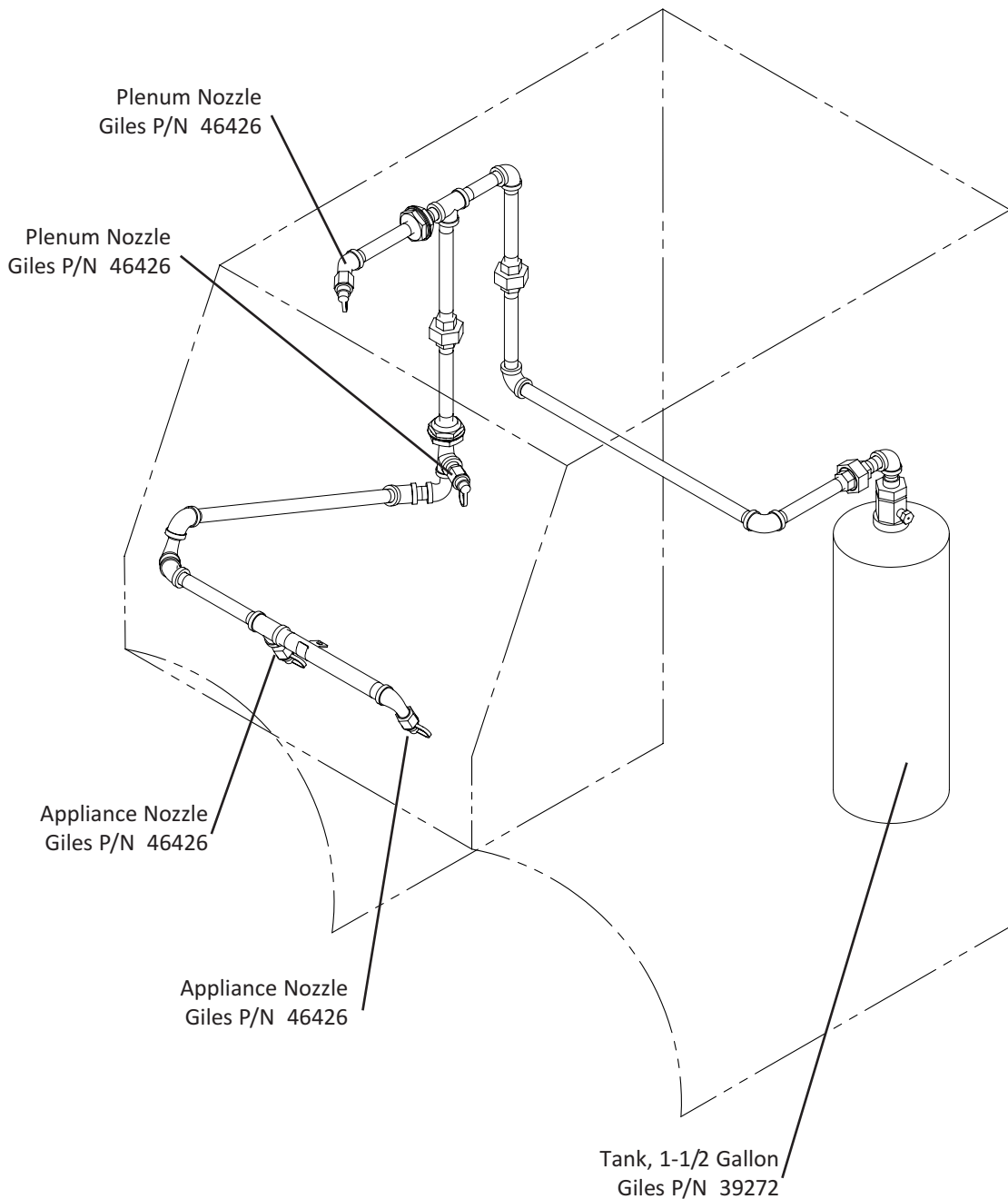

3. Overview

The following section provides a brief overview of the components, functions, and accessories of the Model WOG-20MP and WOG-20MP-VH Fryer. Please review this section carefully before proceeding any further.

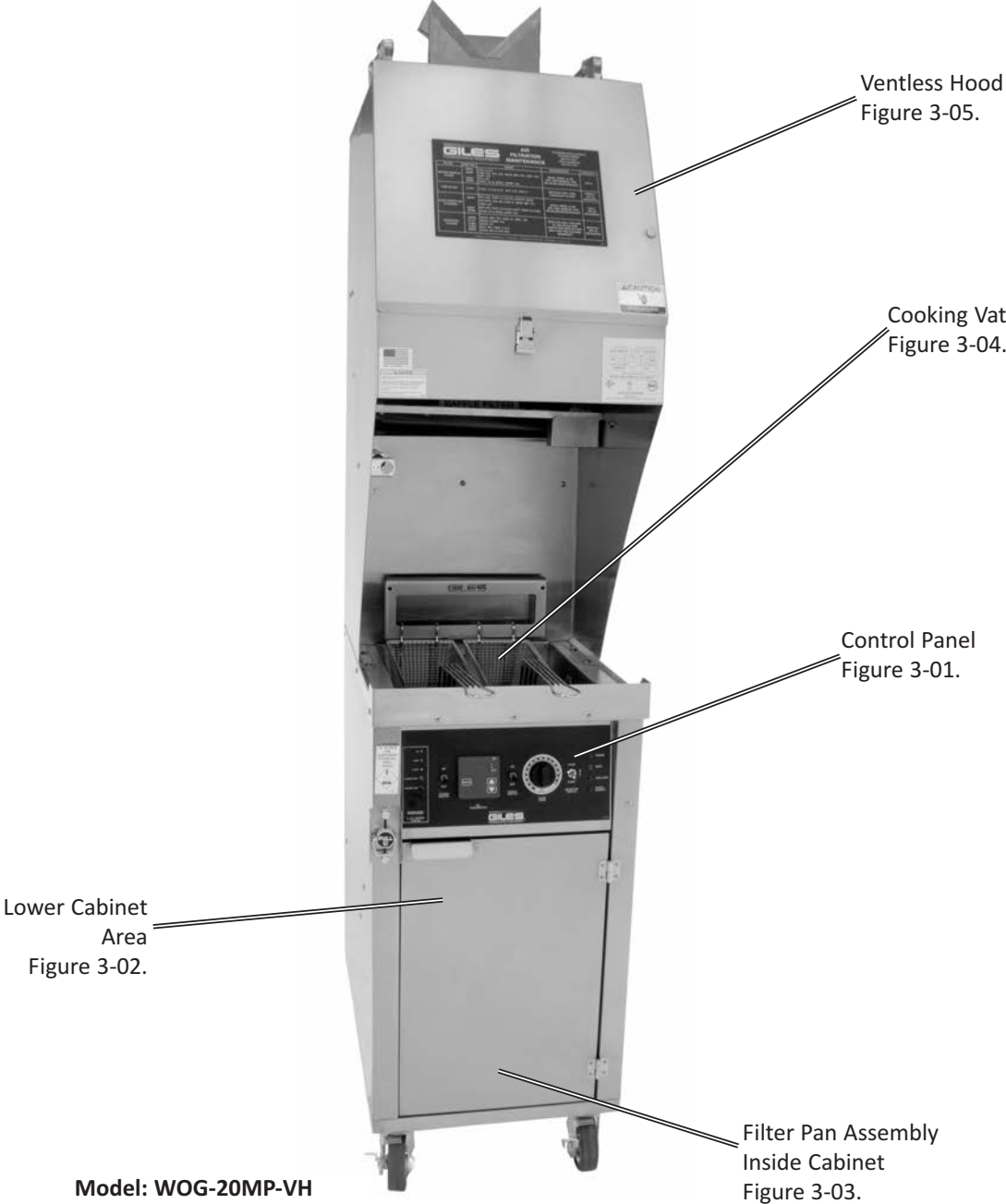

Model: WOG-20MP-VH

3-01. Cooking Vat

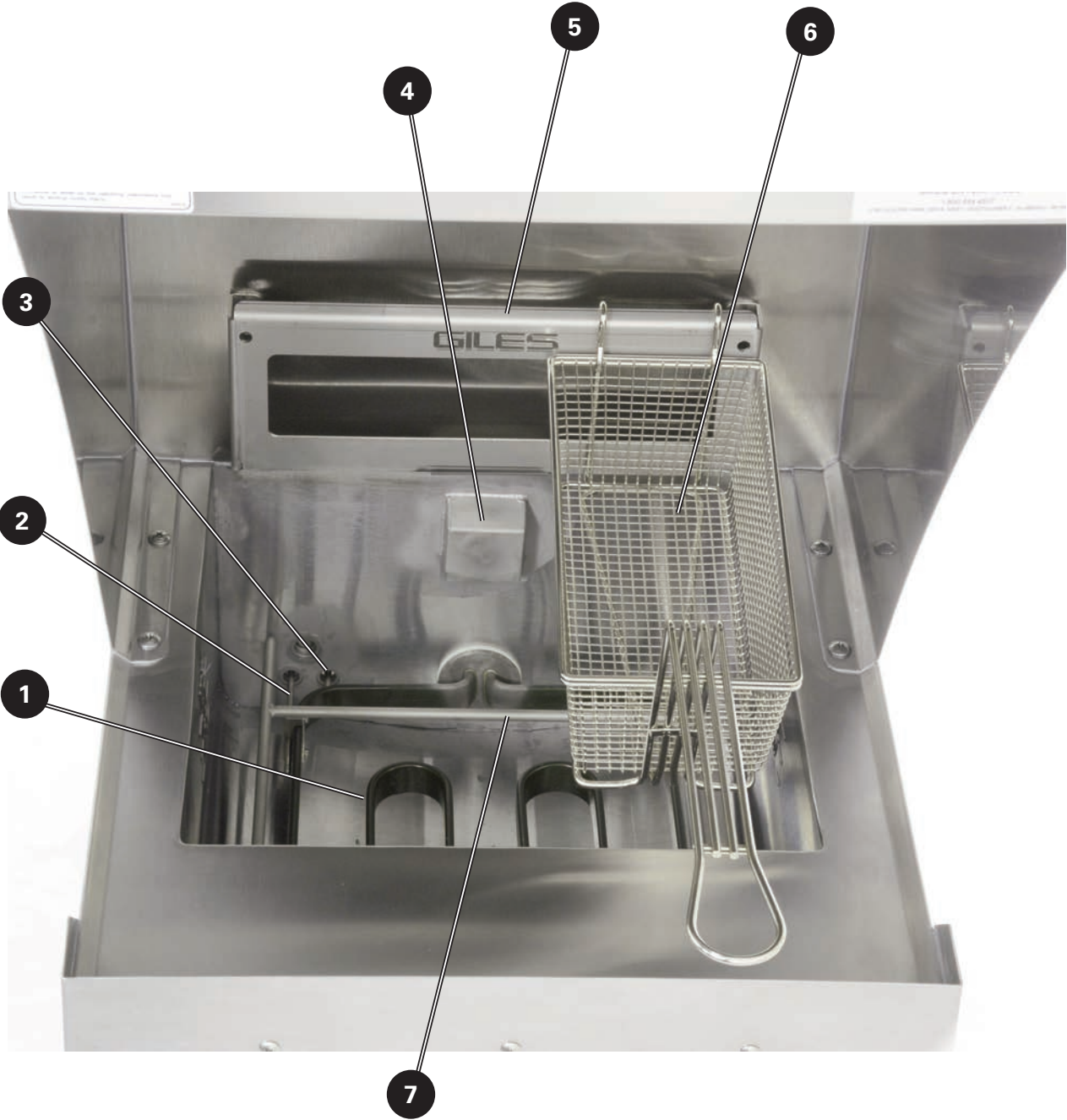

3-01. Cooking Vat		
Item	Description	Function
1	Heating Element	Heats cooking oil and maintains it at the set cooking temperature.
2	Hi-Limit Temperature Probe	Connects to the High-Temperature Safety Thermostat control, which prevents cooking oil from overheating due to possible temperature control malfunction. If this probe detects oil temperature rising to 425°F, power to the Heating Element will be shutdown and the red Hi-Limit Indicator Light will turn <b>ON</b> .
3	Variable Temperature Probe	Senses cooking oil temperature for the cooking temperature controller.
4	Cooking Oil Return	Oil being returned to the Cooking Vat during the filtering process is delivered through this port. The hooded cover helps to minimize splash and splatter.
5	Basket Hanger	Holds the Cook Baskets above the cooking oil for loading fresh product and draining the cooked product.
6	Cook Basket	Contains food product for cooking. Two (2) baskets are provided.
7	Basket Support	Provides support for the Cook Baskets when cooking, preventing them from touching the Heating Element.

## 3-02. Control Panel - Standard



\* WOG-20MP-VH Ventless Hood Models Only  
 \*\* WOG-20MP-VH ... ILS Models Only

3-02. Control Panel - Standard		
Item	Description	Function
1*	Fire Extinguisher Manual Pull Handle	In case of an accidental cooking vat fire, pulling this handle will manually actuate the fire suppression system. Fire system also automatically actuates.
2	High-Limit Indicator	Illuminates when power to the heating element is shutdown by High-Temperature Safety Thermostat control. Should this light come on during operation, refer to the Troubleshooting Section of this manual. <b>DO NOT CONTINUE ATTEMPTING TO COOK IN A FRYER THAT CONTINUALLY HAS HIGH-LIMIT ALARMS!</b>
3	Heat Indicator Light	The Amber Heat Indicator Light will be illuminated when the heating elements are energized. It is normal for the light to cycle ON and OFF as oil temperature is controlled to setpoint.
4	Power Indicator Light	The Green Power Light is on whenever the Fryer's Power Switch is in the ON position.
5	Power Switch	The main appliance Power Switch. Toggle the switch up to the ON position for operation.
6	Digital Thermostat	Controls the cooking oil temperature ... setpoint is adjustable up to 375°F. Pressing & holding the PROCESS key will display actual oil temperature.
7	Signal Switch	Works in conjunction with the Cooking Timer. In the ON position, an end of cycle alarm is enabled and will sound when time expires. Placing in OFF position silences the alarm. As long as switch is in the OFF position, alarm is disabled and will not sound.
8	Cooking Timer	30 minute mechanical Timer. Rotate knob to set cooking time. Time begins counting down when knob is release. <b>NOTE: The Signal Switch must be placed in the ON position if an end of cook cycle alarm is desired.</b>
9	Selector Switch	Select Fryer mode of operation ... COOK, OFF or PUMP. The heating elements are enabled to operate when switch is in the COOK position. The switch is placed in the PUMP position to activate the Filter Pump to filter cooking oil.
10*	EAC Status ON	The ON Indicator Light is on when the Electronic Air Cleaner (EAC) power supply is on and operating normally.
11*	EAC Status WASH/CHECK	The WASH & CHECK Indicator Lights illuminate to indicate an alarm condition with the EAC system. The EAC Cell is excessively dirty, shorted out, making poor contact, faulty component, etc. Power to heating element will be shutdown after approx. 2 minutes after these lights turning ON. <b>DO NOT</b> use these lights as a signal for routine cleaning ... the cell must be cleaned <b>DAILY</b> to maintain peak performance.
12*	Filter Missing	Illuminates when either, or both, the Grease Baffle Filter or the Charcoal Filter are not installed or improperly positioned.
13**	Push to Start Button (ILS Only)	After the Power Switch is in the ON position, press and hold the PUSH TO START Button for 5 seconds to start the appliance & Hood fan (ILS Only).
14*	EAC Cleaning Timer CHANGE SOON	Illuminates when the EAC Cleaning Timer has entered <b>WARNING</b> mode. EAC Cell needs to be cleaned, or exchanged with a clean Cell, within the next 24 hours.
15*	EAC Cleaning Timer CHANGE NOW	Illuminates when the EAC Cleaning Timer has expired and entered <b>TIMEOUT</b> mode. EAC Cell must be cleaned, or exchanged with a clean cell, immediately. An audible alarm also sounds and the appliance is shutdown until the task is performed.
16*	EAC Cleaning Timer SNOOZE Button	Press button to cancel <b>TIMEOUT</b> mode for a period of 2 hours, allowing the appliance to continue operating in order to finish a cook cycle or to meet sales demand. Only two (2) snooze periods may be used before shutdown occurs.

\* WOG-20MP-VH Ventless Hood Models Only

\*\* WOG-20MP-VH ... ILS Models Only

3-03. Lower Cabinet Area



3-03. Lower Cabinet Area		
Item	Description	Function
1	Quick Disconnect - Filter Pan Hose	Connects the Filter Pan Hose to the unit's oil filtration system.
2	Drain Valve Handle	Operates the Drain Valve of the Cooking Vat. Be sure the valve is closed prior to adding cooking oil or boil out solution. As a safety feature, the heating element will not heat if the drain valve is not completely closed.
3	Diverter Valve Handle	Directs the Filter Pump discharge to either the Cooking Vat or the Oil Discharge Hose.
4	Cabinet Door	Provides access all lower cabinet functions.
5	Quick Disconnect - Oil Discharge Hose	Connects the provided Oil Discharge Hose to appliance for purpose of removing used cooking oil from the fryer.
6	Filter Pan	Collects and holds cooking oil which is drained from the Cooking Vat. Contains filter media for the purpose of routinely filtering cooking oil. See Section 3-04. for further detail. Features a removeable Cover for the purpose of controlling splash and splatter.

3-04. Filter Pan Assembly

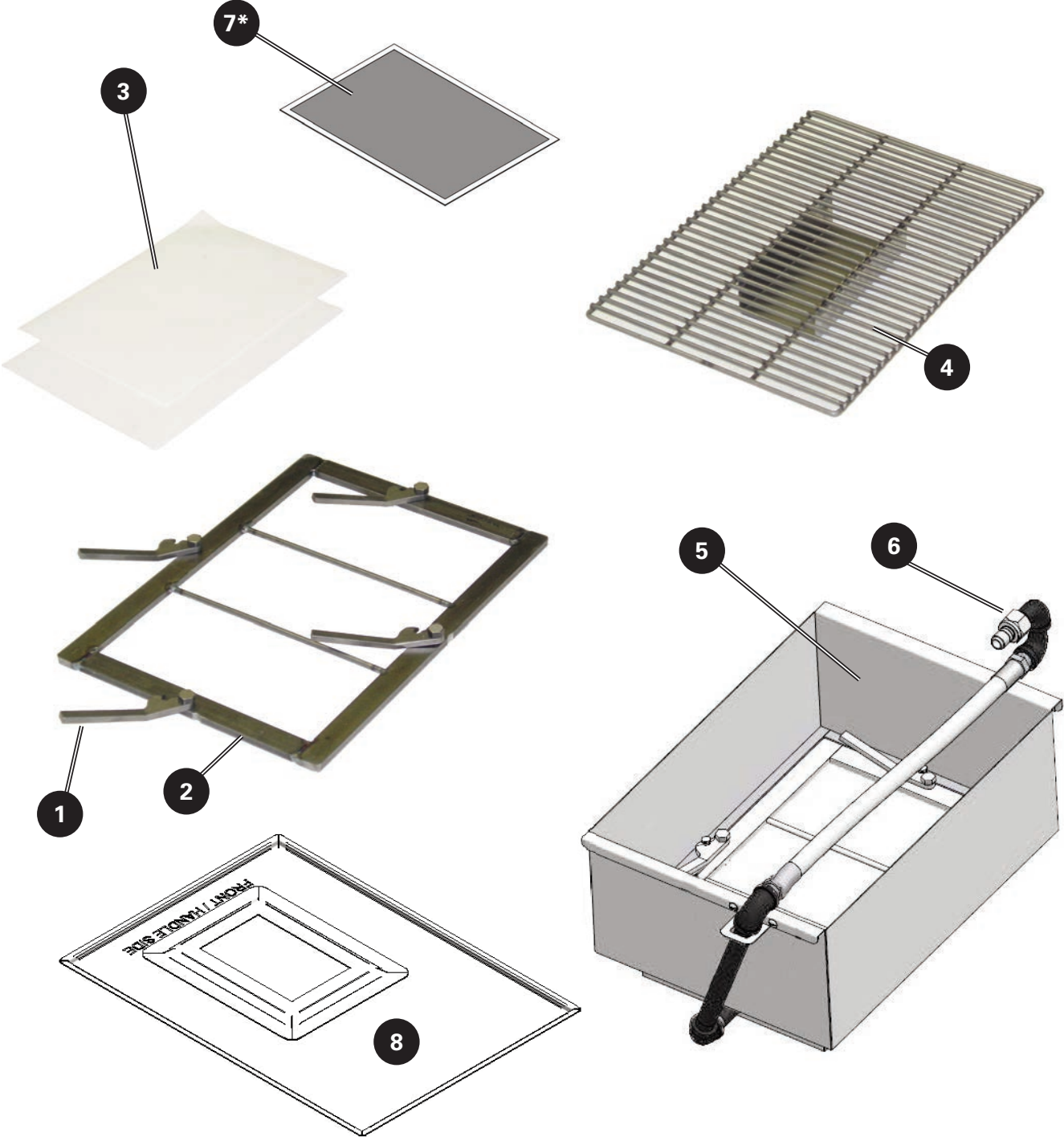

\* Not included, purchased separately

**⚠ WARNING**

Never disconnect and remove the Filter Pan from unit while it contains hot, or warm, cooking oil.

**⚠ CAUTION**

Always use Personal Protective Equipment, such as Thermal Oven Mitts, when working with the Filter Pan ... parts will be very hot when unit is in operation.

3-04 . Filter Pan Assembly		
Item	Description	Function
1	Hold-Down Lever (4 levers)	Secures the Hold-Down Frame tightly against the filter media in the Filter Pan bottom.
2	Hold-Down Frame	Holds the filter media tightly.
3	Filter Media Paper (2 sheets required)	Filters cooking residue from the cooking oil. When used with an appropriate filter aid, such as Giles Filter Powder, the oil is also reconditioned by removal of fatty acids, which can increase the useful life of oil by as much as 50%. The system requires the (2) sheets be used.
4	Filter Pan Screen	Supports the filter media above the bottom of the Filter Pan to allow proper pumping and filtration.
5	Filter Pan	Collects and holds cooking oil drained from the Cooking Vat. Contains the filter media used for filtering the oil. The Filter Pan is removable for cleaning and refreshing the filter media.
6	Filter Pan Quick Disconnect Hose	Connects the Filter Pan to the oil filtration system. The hose must be disconnected for Pan removal.
7*	Stainless Steel Micro-mesh Filter Screen <b>(Purchased Separately)</b>	Alternate filter media ... Replaces paper filter media; cleanable and reuseable. <b>Giles P/N 41020</b>
8	Filter Pan Cover	Sits atop the Filter Pan to help contain splash and splatter when draining cooking oil into the Filter Pan for the filtering process or to remove used oil from the Fryer. Also is a guard to help prevent foreign material from falling into the Pan.

\* Not included, purchased separately

3-05. Ventless Hood Section (WOG-20MP-VH)

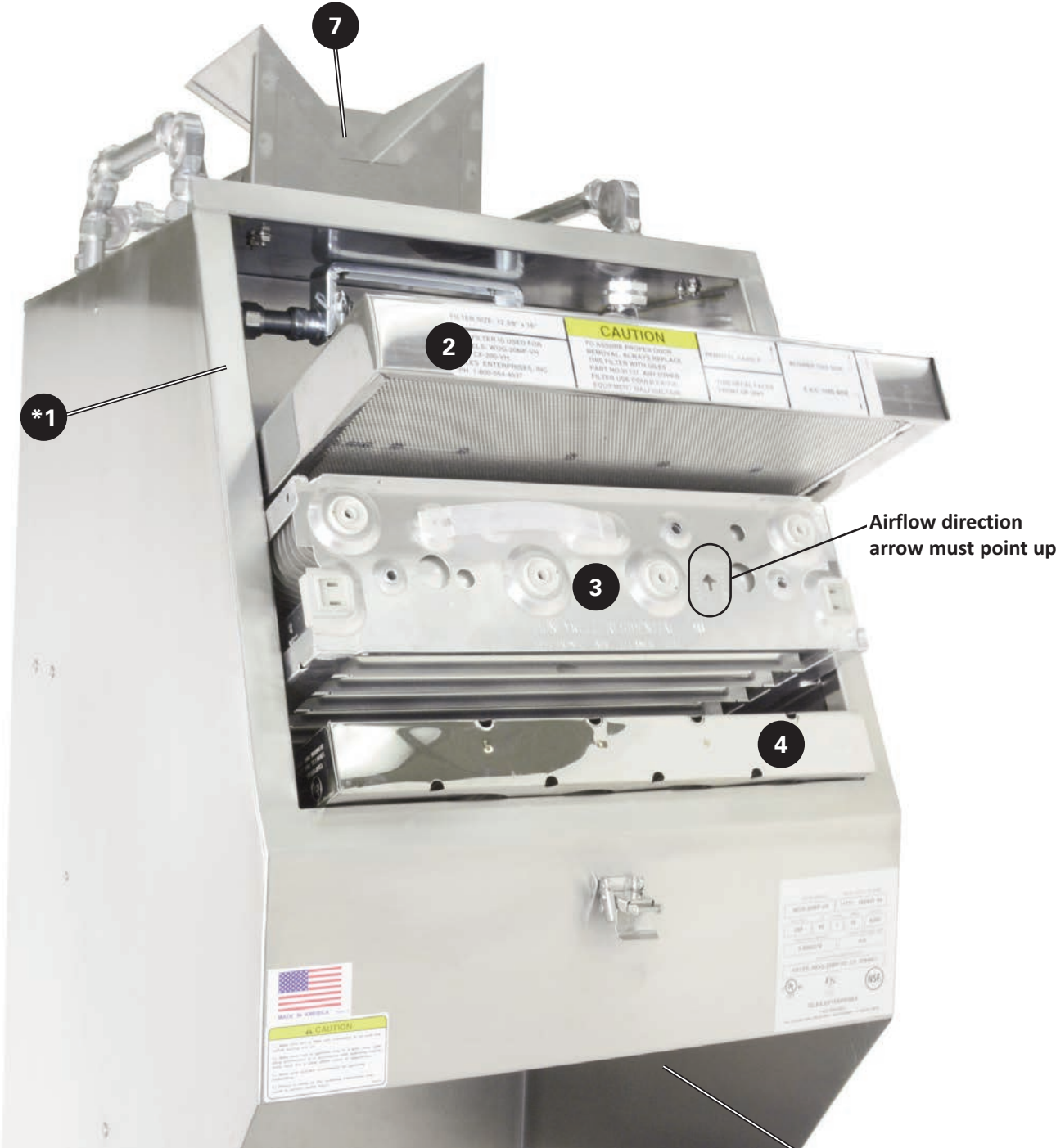







\* Not Shown

5\*  
6\*

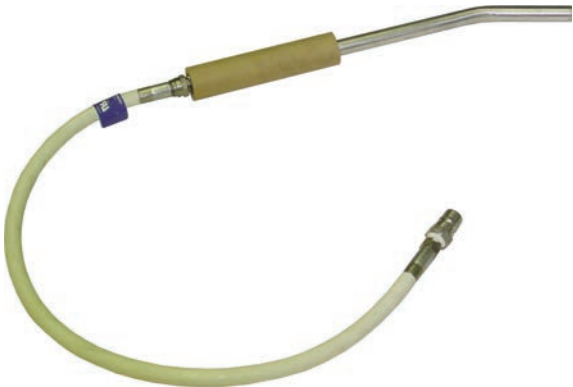

3-05. Ventless Hood Section (WOG-20MP-VH)		
Item	Description	Function
1*	Hood Filter Cover	Access to the Filter Chamber and all Filters (Baffle, EAC Cell & Charcoal). The Cover must be in place and latched before the unit will power-up and removing the Cover during operation will cause the appliance to shutdown.
2	Charcoal Filter	Helps remove aromas and odors generated during cooking to freshen the discharged air. This is a one-use, consumable Filter and typically, should be replaced monthly. <b>NEVER attempt to clean and reuse the Charcoal Filter.</b> Keep a spare Filter on hand for quick exchange when needed (Giles P/N 31963).
3	EAC Filter Cell	The EAC Filter Cell is an electrostatic device which captures fine grease particulate generated by the fryer during cooking. <b>Appliance power must be turned OFF before removing the EAC Cell for cleaning. The Cell should be cleaned daily to maintain peak performance.</b>
4	Baffle Filter	The Baffle Filter is the first stage of the air-cleaning system. It captures large grease particulate and drains it into a Drip Cup. Filter is easily removed for daily cleaning.
5*	Grease Drip Cup	Collects and holds grease condensate generated at the Baffle Filter. This cup should be inspected and cleaned daily, or as needed.
6*	Grease Drip Cup Safety Shackle	Secures the Grease Drip Cup in its bracket to prevent the cup from accidentally falling.
7	Exhaust Stack w/Diverter	3-way Diverter directs discharge air to the rear and sides of the unit. There is no ceiling clearance requirement to the top of the Diverter, but it is recommended that a sufficient clearance be allowed to facilitate movement of the appliance, if needed. <b>DO NOT</b> block or obstruct the area around the Diverter openings; doing so could restrict airflow through the hood and reduce capture performance.

\* Not Shown

3-06. Accessories (Included)		
Part	Description/ Part Number	Function
	Kettle Drain Brush P/N 71025	Used for cleaning the Fry Pot.
	Stir Paddle P/N 77775	Used for stirring hot oil and the product when cooking.
	Pot Brush P/N 71100	Used for cleaning Fry Pot and Elements.
	Crumb Shovel P/N 30059	Used for removing sediment from the Filter Pan.

3-06. Accessories (Included)		
Part	Description/ Part Number	Function
	<p>L- Shaped Brush P/N 73233</p>	<p>Used for cleaning between and underneath heating elements.</p>
	<p>Oil Discharge Hose P/N 33667</p>	<p>Used for removing liquid shortening from unit.</p> <p><b>Warning: DO NOT use to wash down cooking vat!!!</b></p>
	<p>Soak Tank P/N 39327</p> <p><b>Model WOG-20MP-VH Only</b></p>	<p>Used for cleaning the EAC Filter Cell.</p>

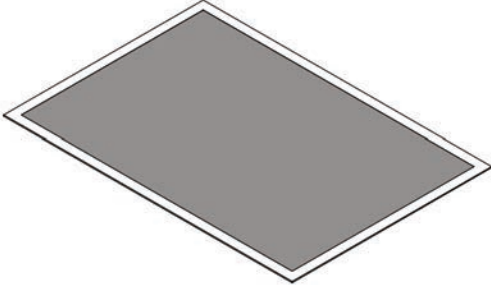
3-07. Accessories (Not Included)		
Part	Description/ Part Number	Function
	<p>Filter Paper P/N 72002</p>	<p>Paper filter media for use in the Filter Pan to filter cooking oil.</p>
	<p>Filter Powder P/N 72004</p>	<p>Filter aid which helps to recondition cooking oil during the filtration process.</p>
	<p>Fryer Boil-Out P/N 72003 (Case of 4, 8-lb Containers)  P/N 72003-1 (Single 8-lb Container)</p>	<p>Mix with water in the Cooking Vat to clean vat and heating element.</p>

3-07. Accessories (Not Included)		
Part	Description/ Part Number	Function
	<p>Stainless Steel, Micro-mesh Filter Screen (for Filter Pan) P/N 41020</p>	<p>Cleanable, reusable, mesh filter media that replaces filter paper in the Filter Pan. Reduce operational cost and trash.</p>
	<p>Giles Oil Caddy P/N 79187</p>	<p>Portable oil disposal container with capacity of 80-lbs of liquid shortening.</p> <p><b>Note: To be used with filtered, warm oil only. No crumbs or debris.</b></p>



## 4. Unit Preparation

Giles Enterprises, Inc. takes pride in the quality of our workmanship. Every effort has been made to ensure that this new appliance is in good operating condition when received. Each unit passes rigorous quality control inspection and testing prior to shipment. To further ensure trouble-free operation of the new unit, we recommend performing a brief operational check.

### IMPORTANT!

Before attempting to operate the unit, refer to Section 3 to become familiar with the various control functions of the appliance. Once you have read and fully understand Section 3, please follow the steps below precisely in order to prevent equipment damage.

### 4-01. Setting the Unit for Testing

Be sure that the appliance controls are set-up as follows before proceeding with the preliminary test.

1. Be sure the Power Switch **1** is placed in the **OFF** position.
2. Be sure the Selector Switch **2** is placed in the **OFF** (center) position.



3. Open the Cabinet Door and remove the Filter Pan.
4. Be sure the Drain Valve Handle **3** is in the **CLOSED** (horizontal) position.
5. Be sure the Oil Diverter Valve **4** is in the **TO FRYER** (vertical) position.
6. Remove Baskets from vat.



## 4-02. Power Test

The following test will confirm that the unit is powered.

1. Set-up the unit as explained in **Section 4-01**.
2. Be sure the circuit breaker in the main electrical panel providing power to the unit is **ON**.
3. Place the Power Switch **1** in the **ON** position. The green **POWER** light **2** will turn on. If unit is a Ventless Model WOG-20MP-VH, the hood fan will start when power is **ON**. Please proceed to **Section 4-03**.



**NOTE:** If the unit is a Ventless Model WOG-20MP-VH with the ILS Option, the PUSH TO START button above the Power Switch must be pressed and held for 5 secs before the appliance will power up.

If the **POWER** Light does not turn on and/or fan in Ventless model does not start, refer to the Troubleshooting procedures in **Section 8-01**.

## 4-03. Heating Element Test

The following test will confirm that the Heating Element is being powered and is heating.

### **CAUTION**

**DO NOT touch the Heating Element during this test. The Heating Element becomes very hot and bare skin contact with it may result in a severe burn injury.**

1. Set-up the unit as explained in **Section 4-01**.
2. Be sure that the Power Switch is in the **OFF** position and the Heating Element is at room temperature.

## 4-03. Heating Element Test (continued)

- Using a sponge, liberally dampen the Heating Element **1** with clean water.
- Place the Power Switch **2** in the **ON** position.

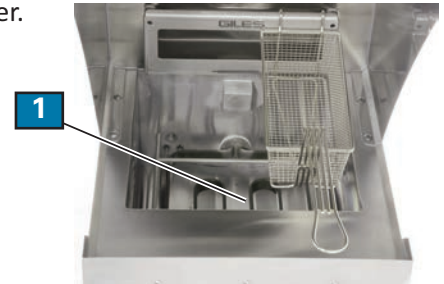

- Press the arrow keys on the digital Thermostat to change the temperature setpoint to around 300°F **3**. Refer to **Section 5-03.1, Setting a Cooking Temperature**.
- Place the Selector Switch **4** in the **COOK** position. It is **IMPORTANT** that the Switch **DOES NOT** remain in the **COOK** position for **MORE THAN 10-15 SECONDS**.
- Return the Selector Switch to the **OFF** position (centered).
- The wet element should quickly dry and heat should be detected rising from the vat. Proceed to **Section 4-04**. If the Heating Element does not dry within 15-30 seconds and/or no heating is detected, refer to the Troubleshooting procedures in **Section 8-01**.

## 4-04. Filter Pump Test

The following test will confirm that the Filter Pump is operating correctly.

1. Set-up the unit as explained in **Section 4-01**.
2. Place the Power Switch **1** in the **ON** position.
3. Open Cabinet Door.
4. Place the palm of the hand over the Quick-Disconnect **2** at the Filter Pan Connection.
5. Place the Selector Switch **3** in the PUMP position. Allow the Pump to run for a few seconds, then return Switch to the **OFF** position. If suction is felt at the disconnect connector, the pump is operating correctly. Proceed to **Section 4-05**.



If the Pump does not run or no suction is felt, refer to the Troubleshooting procedures in **Section 8-02**.

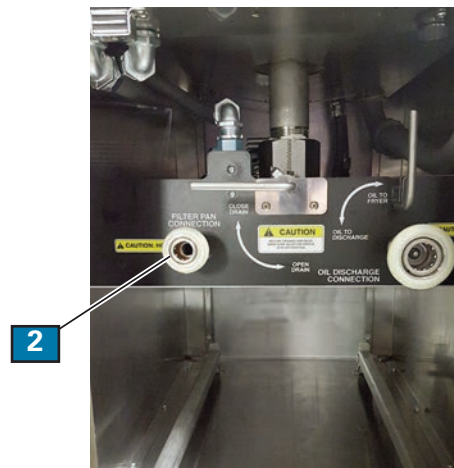

## 4-05. Perform Boil Out Procedure

Before cooking with the new appliance, first perform the Boil-Out Procedure to remove any dirt or debris that may have collected in the unit during shipping and/or storage. This process also will remove any residue or oils that may remain from manufacturing processes. Refer to **Section 6-01, Boil-Out Procedure**. After performing the Boil-Out Procedure proceed to **Section 4-06**.

## 4-06. Initial Cleaning of the Appliance

1. Disassemble the Filter Pan and wash all of the components in warm soapy water to remove any dirt or debris that may have collected during shipping and/or storage, and any residue from manufacturing processes. Rinse and dry thoroughly before reassembling, being sure all water is drained from the Filter Pan piping and hose. Refer to **Section 6-02, Cleaning the Filter Pan & Replacing Filter Paper After Boil-Out.**
2. Wash all accessory items (baskets, stir paddle, crumb scoop, etc.) in warm soapy water before using.
3. Check the entire appliance to locate and remove any of the protective adhesive poly-film that may still remain on the appliance from the factory. Some of this film is intentionally left on surfaces as protection during shipping.
4. Using a good quality stainless steel cleaner/polish, wipe down all exterior surfaces to clean away dust and any residues remaining from manufacturing processes.

### Notes:

# Model: WOG-20MP &WOG-20MP-VH



## 5. Fryer Operation

The following section explains operation of the Giles Electric Fryer, Model WOG-20MP and WOG-20MP-VH. Designed for easy operation, the unit has a 30-minute mechanical Cook Timer with a easy to use digital solid-state Thermostat. Before attempting to operate this appliance, please take the time to become familiar with the processes presented in this section.



Model: WOG-20MP



Model: WOG-20MP-VH

## 5. Fryer Operation

 **DANGER**

- Turn off Fryer power switch and appropriate circuit breaker in the main electrical panel providing power to the appliance before cleaning or performing maintenance.
- DO NOT hose down Fryer interior or exterior with water from a spray hose.
- Failure to comply with DANGER notices will result in death or serious injury, damage to equipment or property, and will void the warranty!

 **CAUTION**

- Ensure the unit is positioned in a stable, secure and safe location, that the casters are locked, and that an appropriate restraint cable is installed, as required, to prevent unintended movement.
- Consult an electrician to confirm that installation meets all electrical specifications and that the unit is properly grounded. The wiring diagram provided with this unit should aid an electrician or technician during installation of the equipment.
- Due to the high temperature of oil during cooking activities, it is extremely important that the user exercise due caution when operating and working with this equipment in order to avoid personal injury.
- This appliance is not intended for use by persons (including children) with reduced physical, sensory, or mental capabilities, or lack of experience and knowledge, unless they have been given adequate instruction and/or supervision concerning its use by a person responsible for their safety. Children should be supervised, or otherwise restricted, to ensure they do not play with or around this appliance.

## 5-01 Cooking Control - Overview

The following section provides instructions for operating and setting the **Electro-Mechanical Cooking Controls**.

Digital Thermostat Control

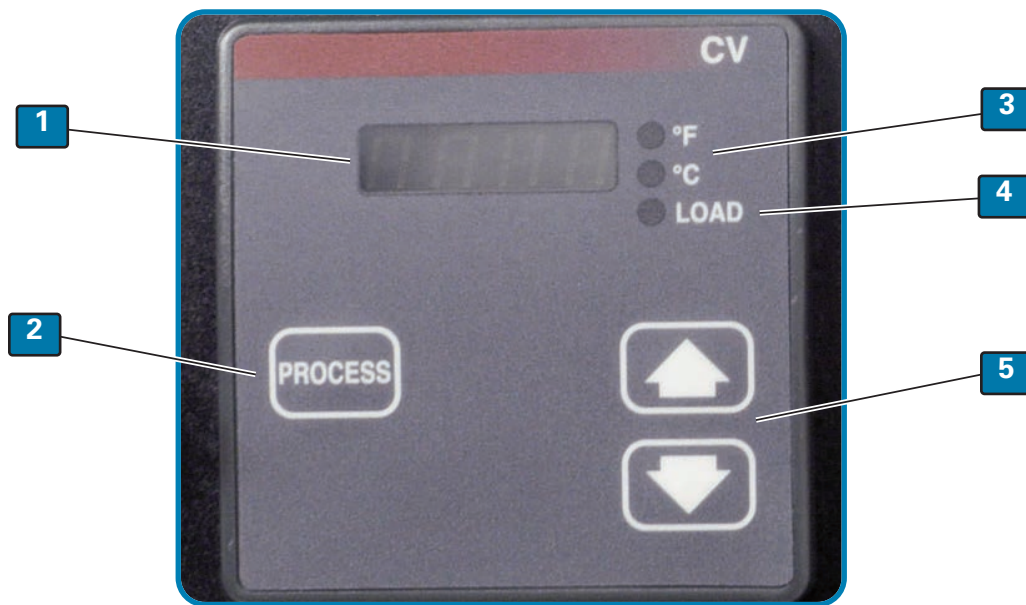

- 1 Main Display** Primarily displays temperature set-point value. Pressing and holding the **PROCESS** key will display actual oil temperature until released.
- 2 PROCESS Key** Press and hold to view current actual oil temperature.
- 3 °F or °C Indicator** Indicates temperature unit the Thermostat displays.
- 4 LOAD Indicator** Illuminates when heating element is energized. Light cycles **ON** and **OFF** during operation.
- 5 Arrow Keys** Pressing these keys increment or decrement a displayed value when changing settings. A new value automatically becomes effective 3 seconds after the last keystroke. These keys are inactive if the **PROCESS** key is being pressed; releasing the key re-enables the Arrow Keys.

## 5.01.01 Setting the Temperature Unit

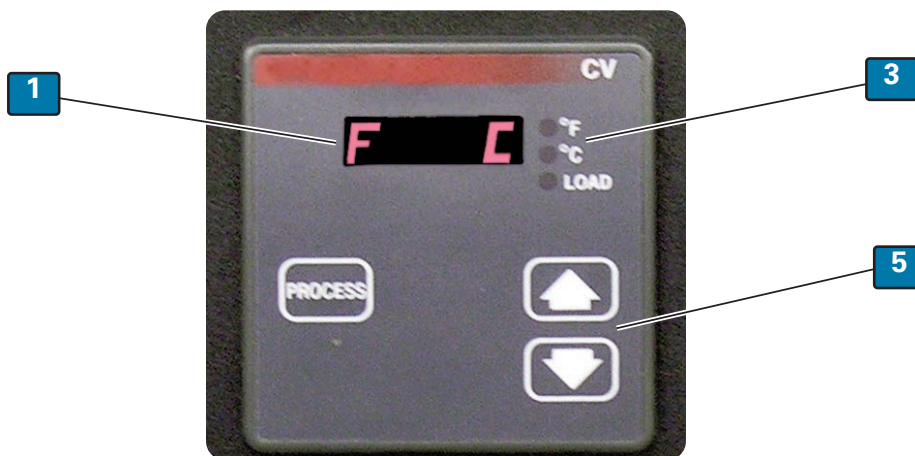

1. To set the temperature measurement unit (**Fahrenheit** or **Celsius**), press and hold both **Arrow Keys** **5** for approximately ten (10) seconds until the Main Display **1** shows **F C**. Within two (2) seconds, use the **Arrow Keys** to set the temperature unit as desired. Without pressing any other keys, the new setting will become effective three (3) seconds after the last keystroke. Within five (5) seconds, the Main Display will blink and return to displaying the set-point value in the unit of measure selected.
2. The appropriate **Temperature Unit Indicator** **3** light will illuminate to show the temperature unit for which the Thermostat is set. **This step should only be required once.**

## 5-01.02 Setting the Cooking Temperature



1. To set, or change, the cooking temperature set-point, simply press the appropriate **Arrow Key** **5** until the desired temperature value is shown on the Main Display **1**. When the desired setting is displayed, press no other key. The new set-point value will automatically become effective three (3) seconds after the last keystroke. **NOTE:** A set-point cannot be set, or edited, while the **PROCESS** key **2** is being pressed.

2. The **Temperature Unit Indicator** **3** shows the temperature unit for which the controller is currently set.

### IMPORTANT!

Be aware that a temperature setting is NOT locked in the Thermostat. Inadvertently pressing the Arrow Keys can unintentionally change the set-point, and consequently the cooking oil temperature.

## 5-01.03 Setting a Cooking Time



1. The mechanical Timer **6** counts down cooking time and sounds an end of cycle signal. Timer range is **0 to 30** minutes.
2. To set a cooking time, rotate the Timer knob until the indicator aligns with the desired cook time. Time will begin running down as soon as knob is released.
3. Place the Signal Switch **7** in the **ON** position. When the cook time expires, an audible alert signal will sound indicating end of cooking time. Place Signal Switch in **OFF** position to silence the tone. **NOTE: If Signal Switch is not placed in ON position, no alert will sound when timer expires.**
3. To cancel a cooking cycle before it finishes, simply turn the Timer knob back to - **0** -.

## 5-02. Cooking Procedure

The following section describes cooking procedures for the appliance.

1. Remove the Cooking Baskets from the unit.
2. Ensure the Power Switch **1** and the Selector Switch **2** are in the **OFF** position.



4. Ensure the Drain Valve Handle **3** is in the **CLOSED** (horizontal) position.
5. Fill the Cooking Vat with good quality liquid frying shortening. Fill only to the **ADD** **4** level at this time; the shortening will expand when heated.

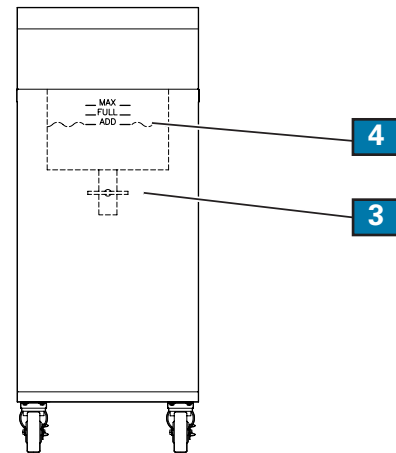

6. Place the Power Switch **1** in the **ON** position. The Power Light **5** will come on.
7. Set the desired cooking temperature as explained in **Section 5-01.2, Setting the Cooking Temperature**.
8. Place the Selector Switch **6** in the **COOK** position. The amber Heat Light **7** will turn on and oil begins pre-heating to the set-point.



## 5-02. Cooking Procedure (continued from previous page)

- Using the provided Stir Paddle, occasionally stir the shortening while it is preheating. This will help remove cool zones in the shortening, resulting in more even heating and cooking of product.
- When the temperature of the shortening reaches the Thermostat set-point, the heating element, and the amber Heat Light **7** will turn **OFF**. To ensure even heating, continue stirring the pre-heated oil until the Heat Light turns **ON** once again, then stir until the light turns **OFF** a second time. The shortening should now be completely pre-heated and ready for cooking.

- Check the shortening level, it should now be at the **FULL** Level **8**. Add liquid shortening if needed, and stir in to heat.

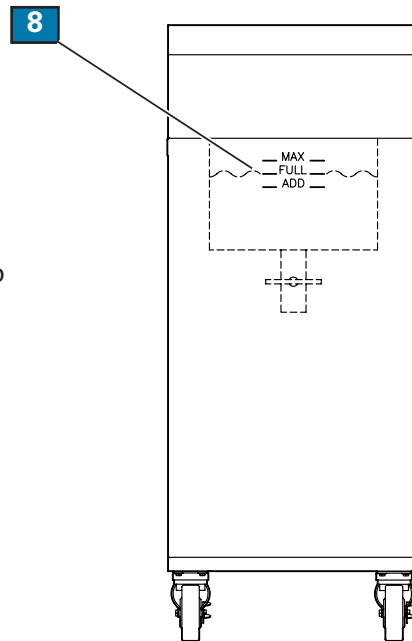

- Place the Cooking Basket **9** onto the Basket Hanger **10**.

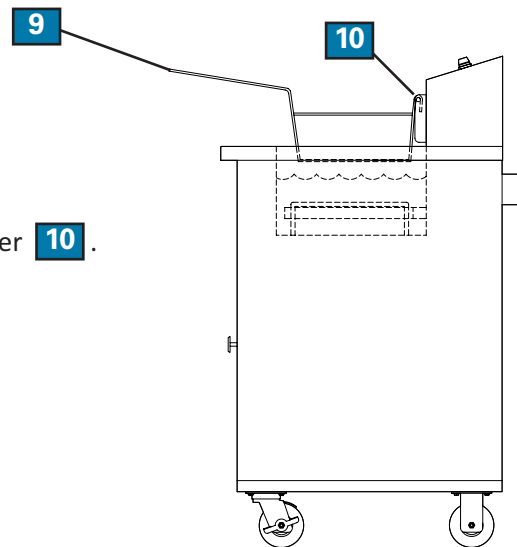

Continued next page 

## 5-02. Cooking Procedure (continued from previous page)

**NOTE:**

Uncooked product may be placed in the Cook Basket either before, or after, the Basket is placed into the hot shortening.

**WARNING**

Use extreme caution when placing product into the **HOT** shortening. Skin contact with hot oil, even splash and splatter, can cause serious burns.

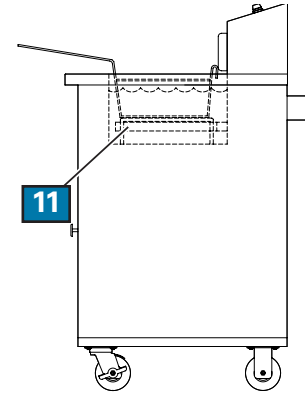

13. Place the Cooking Basket (with or without product) into the shortening, and sit it on the Basket Support Rack **11** in the bottom of the vat. If not already done, carefully place uncooked product into Basket.

14. Place the Signal Switch **12** in the **ON** position.

15. Rotate the Timer Knob **13** to the desired cooking time (0 to 30 mins). Timer begins running down when knob is released.



## 5-02. Cooking Procedure (continued from previous page)

16. After a sufficient amount of the cooking time has elapsed, use the provided Metal Stir Paddle **18** and agitate the cooking product to help prevent product from sticking together, and help ensure that it cooks evenly.

The point in the cook cycle when product needs to be stirred is decided by the user, typically this should be done after approximately 50-60% of set cooking time has expired.

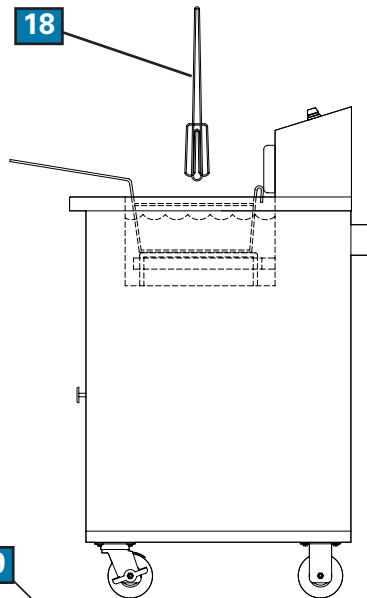

17. When the set cooking time expires, an alert signal will sound. Place the Signal Switch **19** in the OFF position to silence alarm.



18. Wear Thermal Mitts ... lift the Cooking Baskets from the oil and place onto the Basket Hanger **20**.

19. Allow cooked product to drain adequately. Remove the Cooking Basket from hanger and pour the cooked product into an appropriate container or food pan. **Cooked products must be maintained at proper temperature, in accordance with prevailing health regulations.**

20. a.) To continue cooking, return to **Step 11** of this procedure.  
b.) To shut down the unit, see **Section 5-04, Normal Shut-Down.**

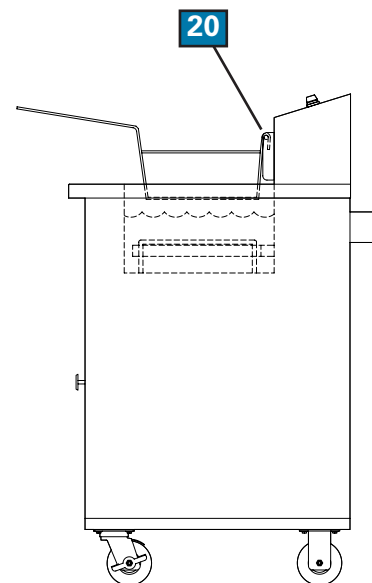

### 5-03. Filtering the Cooking Oil

The following section explains how to filter the cooking oil using the built-in Filter System. This system recirculates used oil through the Filter Pan and filter media, and returns the reconditioned oil to the Cook Vat. By following this process, shortening life can be increased by up to 50%.

#### **⚠ WARNING**

**DO NOT attempt to filter cold, or congealed, shortening. Doing so can clog and possibly damage the filter pump. Shortening must be heated to a minimum of 200°F (93°C) before filtering.**

1. Giles recommends filtering the cooking oil after every fourth (4th) load of product cooked.
2. Ensure that the Power Switch **1** is in the **ON** position, and the Selector Switch **2** is in the **OFF** position.
3. Confirm that cooking oil is heated to at least 200°F (93°C).



#### **⚠ CAUTION**

Parts inside the appliance cabinet will become hot during operation. To reduce potential for personal injury, always wear thermal mitts, gloves or other personal protective equipment (PPE) when handling or working with the Filter Pan, and other components inside the cabinet .

## 5-03. Filtering the Cooking Oil (continued from previous page)

4. Open the Cabinet Door, and while wearing thermal protective gear, disconnect the Filter Pan Hose **3**. Push white slip ring of the disconnect in toward the back, while pulling connector out.
5. Slide the Filter Pan **4** from the unit and remove Pan Cover
4. Confirm that the Filter Pan has (2) sheets of paper filter media installed correctly, and that the surface is clear of residue from previous filtering. A stainless steel mesh Filter Screen may be used instead of paper media.
5. Add one package (approx. 5 ozs) of **Giles Filter Powder (Part No. 72004)** into the Filter Pan; distribute evenly over filter media. **Use of a filter aid is important to the filter process. It helps recondition the oil by removing soluble impurities from oil, which can affect food flavors and oil life.**
6. To contain possible splash and splatter during the filtering process, be sure to replace the Filter Pan Cover. Reposition Filter Pan in the unit and reconnect the Hose **3**. Push white slip ring in toward the back, while at the same time pushing connector into fitting. Be sure that connector is fully inserted and the slip ring is completely engaged. **If this connection is loose, the filter pump will not pump the oil.**



### **⚠ DANGER**

During the following step cooking oil is drained from Cook Vat into the Filter Pan. The appliance is equipped with a Drain Valve safety interlock, which disables the heating element when the Valve is opened, however as additional safeguard to avoiding any potential of fire due to exposed Heating Elements, **ALWAYS PLACE THE SELECTOR SWITCH IN THE OFF POSITION PRIOR TO DRAINING THE COOK VAT .**

8. Be sure the Selector Switch **2** is placed in the **OFF** position. Be sure that the Oil Diverter Valve **7** is placed in the **OIL TO FRYER** (vertical) position. Slowly turn the Drain Valve Handle **8** to the **OPEN** (vertical) position, allowing the used cooking oil to drain from the Cook Vat into the Filter Pan.

### **NOTE:**

If the Cooking Vat does not readily drain, use the provided Drain Brush to break up crumbs or debris that may be blocking the drain. **Be careful not to push the brush down far enough to puncture the filter media in the Filter Pan. A puncture can allow debris to be sucked into pump, clogging and potentially damaging it.**

Continued next page 

## 5-03. Filtering the Cooking Oil (continued from previous page)

9. After the Cooking Vat has completely drained into the Filter Pan, place the Selector Switch **9** in the **PUMP** position.



10. The used cooking oil will begin to circulate from the Filter Pan, through the filter media, and back to the Cooking Vat. Leave the Drain Valve open and allow the oil to circulate in this manner for at least of 5 minutes (minimum). During this time use the provided brushes to remove cooking residue from vat walls and heating elements, allowing it to be flushed into the Filter Pan.

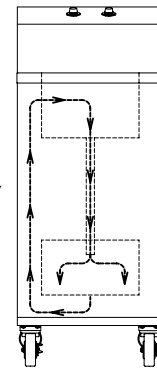

11. When oil has circulated for a minimum of 5 minutes, turn the Drain Valve Handle **10** to the **CLOSE DRAIN** (horizontal) position. Cook Vat will begin refilling.
12. After the Cook Vat has refilled, move the Selector Switch **9** to the **OFF** position.
13. Check the oil level, be sure Vat contains the proper amount of shortening, add if needed.



## 5-03. Filtering the Cooking Oil (continued from previous page)

14. Wearing thermal protective gear, disconnect the Filter Pan Hose **11** . Push white slip ring of the disconnect in toward the back, while pulling connector out.
15. Remove Filter Pan from the unit and remove the Cover. Use the supplied Crumb Scoop **12** to remove sediment from the surface of the filter media.
16. Replace Cover and restall Filter Pan in Fryer.
17. To continue cooking, **See Section 5-2, Cooking Procedure.**  
  
To discontinue cooking, **See Section 5-4, Normal Shut Down.**

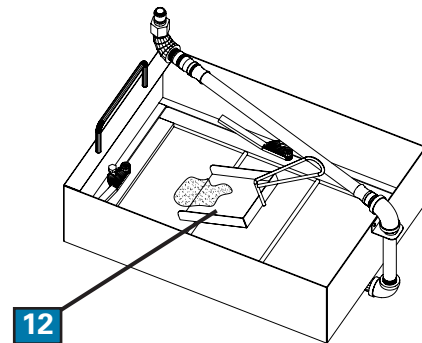

## 5-04. Removing Used Cooking Oil from Fryer

This section describes how to remove used shortening from the unit. This must be done before a Boil-Out Procedure is performed. In this section the Giles Oil Caddy (**not included**) is referenced as the used oil disposal container.

### **WARNING**

**DO NOT attempt to remove cold, or congealed, shortening using this process. Doing so can clog and possibly damage the filter pump. Shortening must be heated to a minimum of 200°F (93°C) before pumping.**

1. If the shortening is cold, heat to 200°F (93°C).
2. Ensure the Power Switch **1** is in the **ON** position.
3. Ensure the Selector Switch **2** is in the **OFF** position.



4. Ensure the Filter Pan **3** is in place and the quick disconnect hose **4** is connected at the fitting.
5. Slowly turn the Drain Valve Handle **5** to the **OPEN DRAIN** (vertical) position and allow the used oil to drain completely from the Cook Vat.

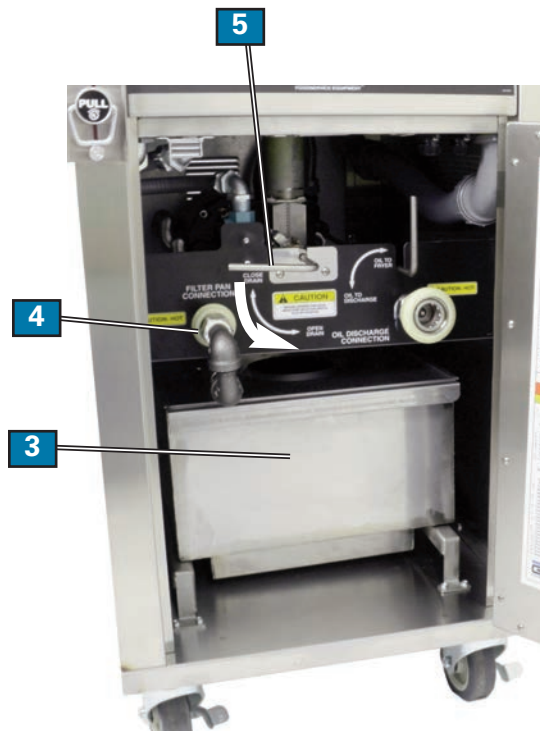

Continued next page 

## 5-04. Removing Used Cooking Oil from Fryer (continued from previous page)

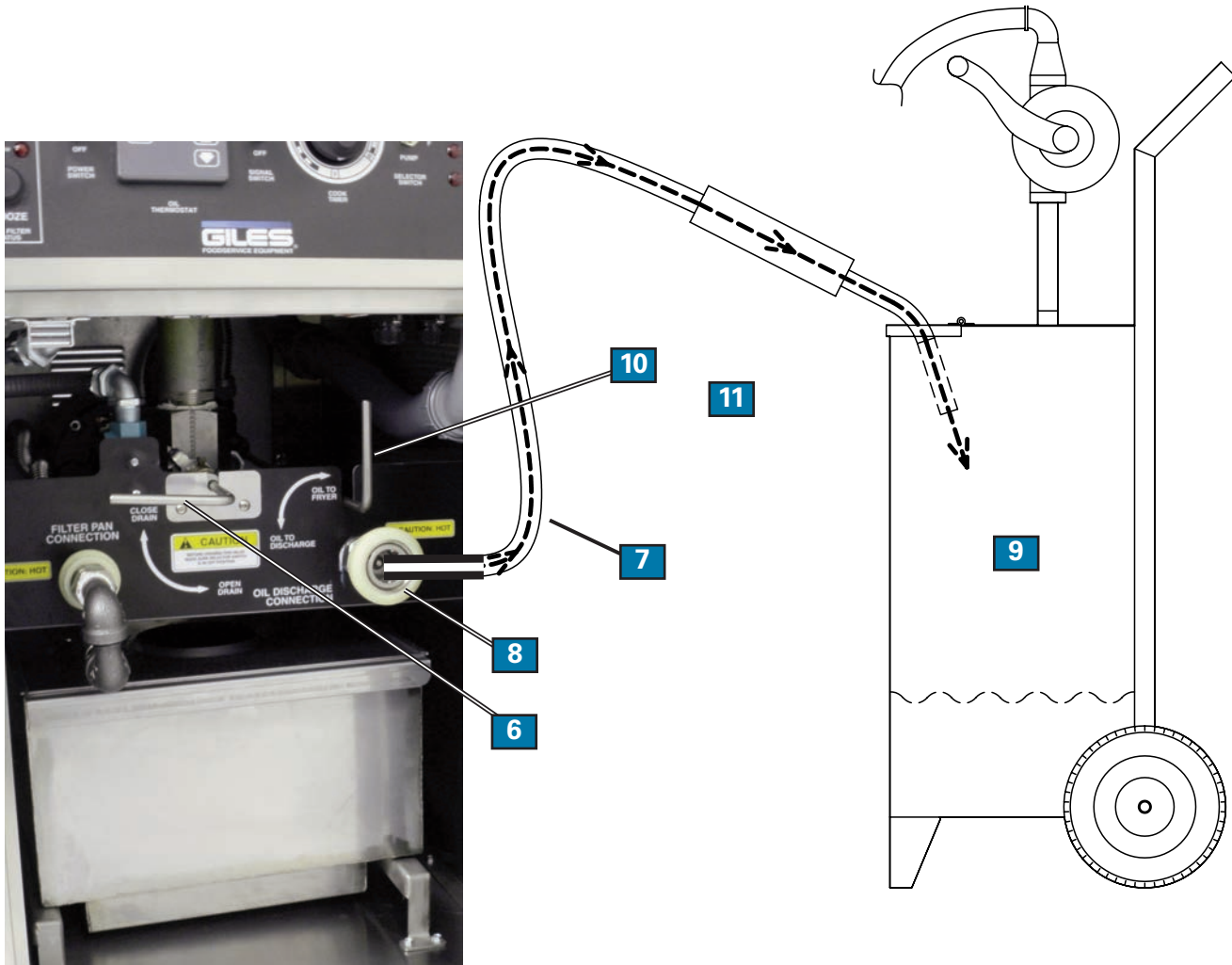

6. After Cooking Vat has drained completely, turn the Drain Valve Handle **6** to the **CLOSE DRAIN** (horizontal) position.
7. Connect the provided Oil Discharge Hose **7** to the Discharge Hose Coupling **8**.
8. Place the discharge end into a hot oil Disposal Container **9** (Giles Oil Caddy is shown).
9. Turn the Oil Diverter Valve **10** to the **OIL TO DISCHARGE** (horizontal) position.
10. **Be sure to wear thermal protective gear when holding the Discharge Hose, as it will become very hot.** Move the Selector Switch **2** to the **PUMP** position, and allow the used shortening to pump into the Disposal Container. Always attend this process to avoid possible hot oil spillage.

Continued next page 

## 5-04. Removing Used Cooking Oil from Fryer (continued from previous page)

- 11. After used oil has been removed from the Filter Pan, move the Selector Switch **12** to the **OFF** position.
- 12. Move the Power Switch **13** to the **OFF** position.



- 13. Turn the Oil Diverter Valve Handle **14** to the **OIL TO FRYER** (vertical) position.
- 14. **Wear thermal protective gear**, remove the Discharge Hose from the Discharge Hose Coupling **15** and drain the all oil remaining in the hose into the Oil Disposal Container.
- 15. Thoroughly clean the Filter Pan and Pan Cover.
- 16. To perform a Boil Out on the unit, see Section **6-01, Boil-Out Procedure**.



To shut down the unit, see **Section 5-04, Normal Shut-Down**.

## 5-05. Normal Shut-Down

1. Place the Selector Switch **1** in the **OFF** position.
2. Place the Power Switch **2** in the **OFF** position, the Power Light **3** will turn off.
4. Turn off supply power to the fryer at the circuit breaker the main electrical panel, as required by local operating procedures.



## 5-06. Emergency Shut-Down

In case of emergency, immediately turn off power supply to the unit by turning off the main facility circuit breaker in the main panel.



Notes:

## Model: WOG-20MP & WOG-20MP-VH



## 6. Cleaning

The following section describes cleaning procedures for the WOG-20MP and WOG-20MP-VH. General cleaning should be performed daily; specific procedures should be done as noted.

### **⚠ DANGER**

- **DO NOT** wash down the appliance interior or exterior with water from a spray hose.
- Failure to comply with these **DANGER** notices will result serious injury, even death, equipment or property damage, and will void the factory warranty.

### 6-01. Boil-Out Procedure (Cleaning the Cooking Vat)

The following explains how to clean the Cooking Vat with a process referred to as a **Boil-Out Procedure**. The Boil-Out must be performed before cooking with the new appliance and should be performed each time shortening is removed from the unit for replacement.

To maintain proper fryer operation, a Boil-Out procedure should be performed, at least, every 10 to 14 days.

### **⚠ DANGER**

- **DO NOT, under any circumstances, leave the fryer unattended during a Boil-Out this procedure. Temperature must be carefully monitored to avoid a possible overflow. Overflow of the Vat may result in serious equipment damage.**

1. Remove the used shortening from the unit, see **Section 5-04, Removing Used Cooking Oil from Fryer**.
2. Be sure the Drain Valve Handle **1** is in the **CLOSE DRAIN**, horizontal position, and the Power and Selector Switches are in the **OFF** position.
3. Fill the Cooking Vat with clean water to the **FULL** level **2**.
4. We recommend using **Giles Fryer Boil-Out (#72003)**. Following the directions on the container, add the proper amount of the Boil-Out powder to the Vat and stir slightly to mix.

### **⚠ CAUTION**

- **If using a cleaner other than Giles Fryer Boil-Out adhere closely to the product use instructions. Many commercially available cleaners contain caustic chemicals, which require special precautions. If used improperly, these chemicals may cause damage to the fryer, and potentially personal injury the user.**

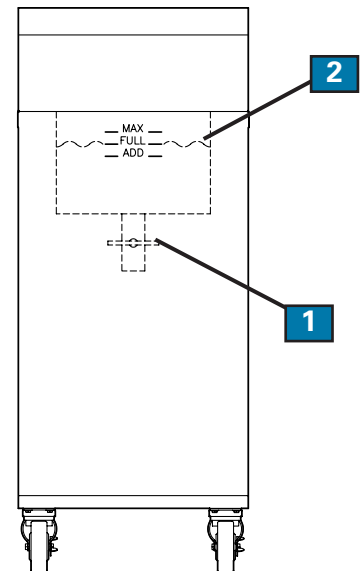

Continued next page

## 6-01. Boil Out Procedure (continued from previous page)

5. Place the Power Switch **3** in the **ON** position.
6. Place the Selector Switch **4** in the **COOK** position.
7. Set the digital Thermostat **5** to **200°F**, see **Section 5-01.2, Setting the Cooking Temperature**. Allow the Boil-Out solution to heat to 200°F.
8. Allow the solution to simmer in the vat as directed (typically 30 mins). A rolling boil should not be allowed. During this time, the Pot Brush can be used to scrub residue from vat surfaces.
9. At the completion of the prescribe time, place the Selector **4** and Power **3** Switches in the **OFF** position.
10. Disconnect Quick Disconnect Hose and remove the Filter Pan from the cabinet.



**Place a Heat Resistant Container Here  
(not provided with unit)  
DO NOT USE THE FILTER PAN!!!**

**WARNING**

- **DO NOT drain the used boil-out solution into Filter Pan!** Contents are corrosive and will cause damage to the Filter Pan, the Hold-Down Frame, and the Filter Pump. Failure to comply may result in minor or moderate injury, equipment/property damage, and void the warranty.

11. Position a suitable **Heat Resistant Container** (not provided with appliance) beneath the Fryer Drain, in place of the Filter Pan.

**CAUTION**

- Always ensure the container which is used for this step is heat resistant up to 300°F (148°C). Plastic is generally not acceptable, as it may melt or break. Leak-proof metal containers are preferable. Failure to comply with this caution may result in serious personal injury.

12. Slowly turn the Drain Valve Handle **5** to the **OPEN DRAIN**, vertical position.

## 6-01. Boil Out Procedure (continued from previous page)

13. Rinse and flush the Vat thoroughly with clean, hot water. Take care to keep the catch container emptied while rinsing the Vat.
14. Completely dry the Vat with clean, dry, sanitized towels.
15. Slowly turn the Drain Valve Handle **5** to the **CLOSE DRAIN**, horizontal position.
16. Clean the Filter Pan and refresh the filter media (paper or screen). Follow directions in **Section 6-03, Cleaning Filter Pan & Refreshing Filter Media after Boil Out**.
17. Position the Filter Pan **6** under the unit and connect the Filter Pan Quick Disconnect Hose **7**.
18. To begin cooking, see **Section 5-02, Cooking Procedure**.

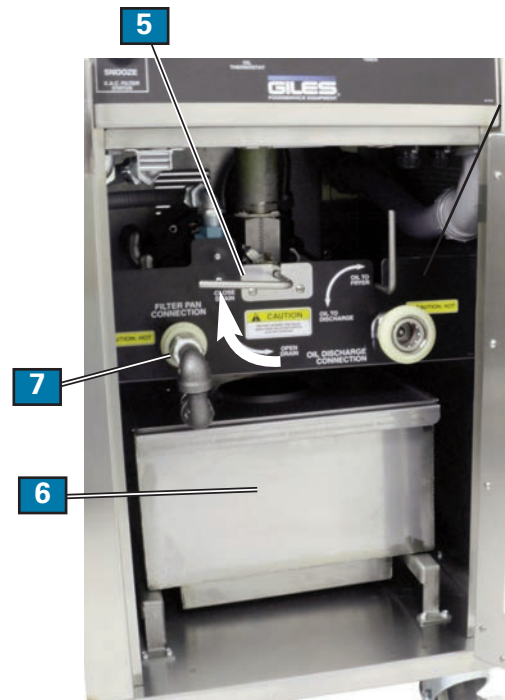

## 6-02. Cleaning Filter Pan & Refreshing Filter Media (Paper) Daily

This section explains the process for cleaning the Filter Pan and the replacing paper filter media. This procedure should be performed daily. It is not necessary to replace filter media after each filtering cycle.

**CAUTION**  
Wear thermal protective gear for protection from hot parts.

1. Follow the normal shut-down procedure, see **Section 5-04, Normal Shut-Down**.
2. Disconnect and remove the Filter Pan **1** and Cover.
3. Use the \*Crumb Scoop provided with the unit to remove the accumulated breading and filter residue from around the edge of the Hold-Down Frame **2** and surface of the Filter Paper **3**.
4. Turn the four Levers **4** to disengage the Hold-Down Frame from the bottom of Filter Pan.
5. Remove the Hold-Down Frame **2**, clean and dry thoroughly.
6. Grasp one end of the top sheet of Filter Paper **3** and carefully roll up, then discard.
7. Grasp bottom sheet of Filter Paper **5** by both ends and remove, retain this sheet for reuse.
8. Remove Ribbed Screen **6** from Pan, clean and dry thoroughly.
9. Thoroughly clean and dry the Filter Pan **7** and the Pan Cover. Be sure that all water is drained from the pipe and flexible hose.
10. Reassemble the Filter Pan using the (1) retained sheet plus (1) new sheet of Filter Paper **8**.
11. Place Cover onto Filter Pan, then reinstall in Fryer and connect hose to fitting.

\* Not shown

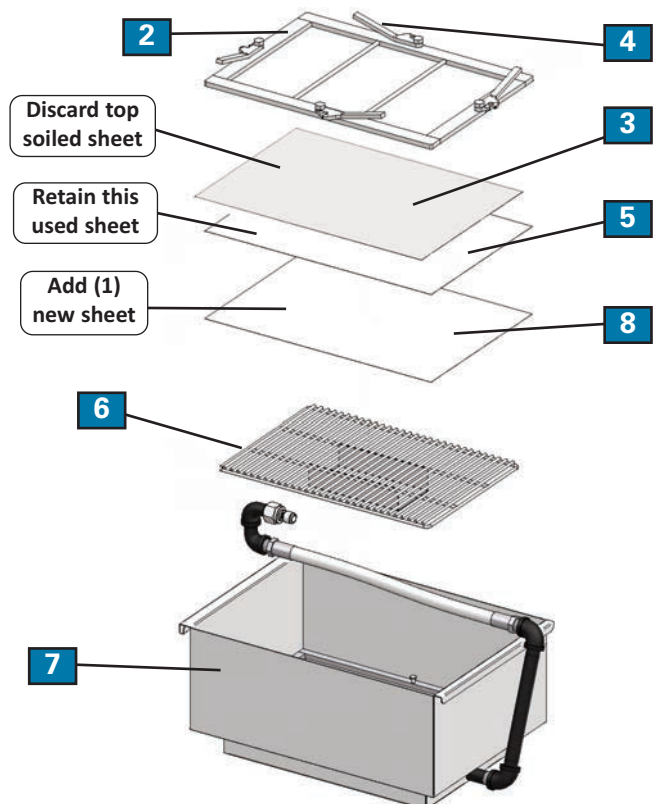

## 6-03. Cleaning Filter Pan & Refreshing Filter Media (Paper) After Boil-Out

This section explains the process for cleaning the Filter Pan and replacing paper filter media. This procedure should be performed after each Boil Out Procedure (Section 6-01), before the Fryer is readied for use.

### **CAUTION**

Wear thermal protective gear for protection from hot parts.

1. Perform the following steps prior to restarting Fryer after the Boil-Out Procedure. Filter Pan should already be removed from the cabinet.
2. Use the \*Crumb Scoop provided with the unit to remove the accumulated breading and residue from the edge of the Hold-Down Frame **1** and surface of the Filter Paper **2**.
3. Turn the four Levers **3** to disengage the Hold-Down Frame from the bottom of Filter Pan.
4. Remove the Hold-Down Frame **1**, clean and dry thoroughly.
5. Grasp one end of the Filter Paper **2** and carefully roll up both sheets, then discard them.
6. Remove the Ribbed Screen **4**, clean and dry thoroughly.
7. Thoroughly clean and dry the Filter Pan **5** and the Pan Cover. Be sure that all water is drained from the pipe and flexible hose.
8. Reassemble the Filter Pan using (2) new sheets of Filter Paper.
9. Place Cover onto Filter Pan, then reinstall in Fryer and connect hose to fitting.

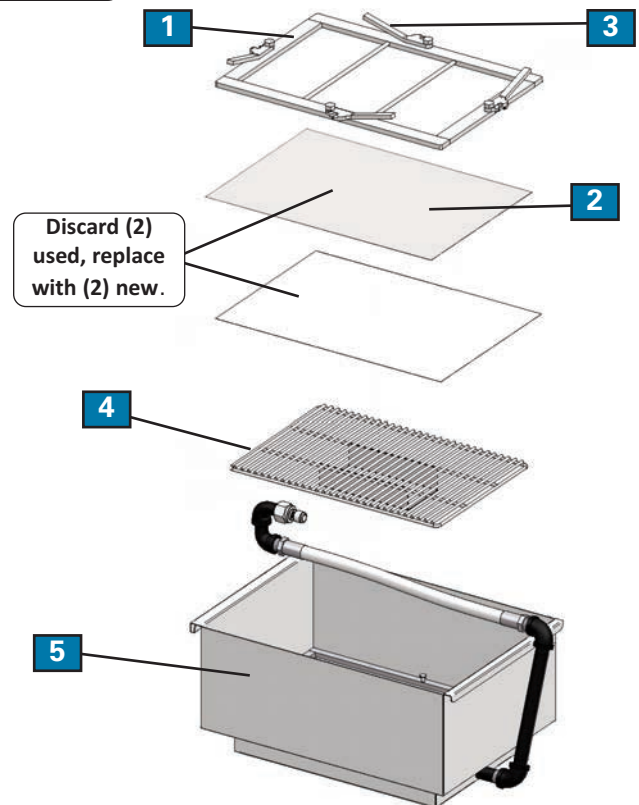

\* Not shown

## Model: WOG-20MP & WOG-20MP-VH



## 7. Ventless Hood

This section applies only to the Ventless Hood (VH) model, WOG-20MP-VH. The following explains operation and maintenance of the Ventless Hood and it's systems. The Hood section contains air cleaning and liquid chemical fire extinguishing systems.

### 7-01. Hood Operation

Make sure all the Filters are properly installed and the fire extinguishing system is armed before operating the unit. For the standard model WOG-20MP-VH, the Hood starts automatically when the appliance is powered up. See steps below for start-up of the **ILS, Push To Start** model.

Place the Power Switch **1** in the **ON** position. The Power Light **2** and EAC ON light **3** will turn on, and the Hood fan will start.

#### Push-To-Start (ILS Model):

Place the Power Switch **1** in the **ON** position.

Press and hold the **Push-To-Start** button **\*4** for 5 seconds; the Power Light **2** and EAC ON light **3** will turn on, and the Hood fan will start.



\* ILS Only, Not Shown

### 7-02. Filters

The following section explains the Ventless Hood Filter System.

#### 7-02.01. Ventless Hood Filter Table

Filter	When to Clean or Replace	How to Remove	How to Clean	How to Install
Baffle Filter	Clean daily	Section 7-02.06	Section 7-02.07	Section 7-02.08
EAC Filter	Clean daily	Section 7-02.08	Section 7-02.11	Section 7-02.09
Charcoal Filter	Replace approx. every 30 days, P/N 31137	Section 7-02.12.	<b>Never clean, only replace</b> Section 7-02.15	Section 7-02.13.

**IMPORTANT! Failure to use Giles OEM Replacement Parts and Filters may void the factory warranty.**

## 7-02.02. Baffle Filter Removal and Installation

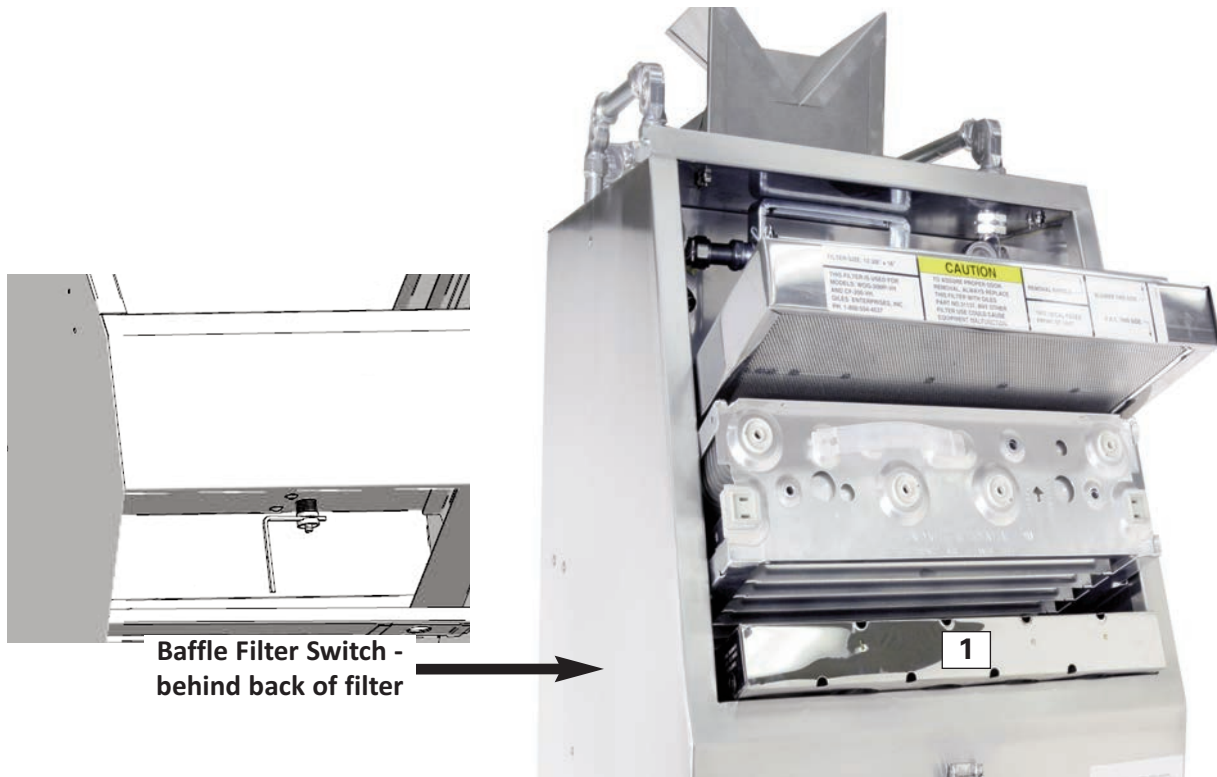

Baffle Filter Switch - behind back of filter

1. Unlatch and lift the Filter Access Cover (not shown) up and off of the Hood.
2. The Baffle Filter **1** simply slides into the filter compartment. To remove, carefully grasp and pull out, at a slight upward angle. **IMPORTANT: The Baffle Filter is constructed of very thin stainless steel sheet metal. Edges of the baffles can be very sharp ... use extreme care when handling and cleaning this filter to avoid personal injury. Use of rubber gloves is recommended.**
3. To replace Filter, align sides with the filter channels inside the compartment and slide it in until it stops. Ensure that the airflow arrow on the filter is pointing **UP**. The back of the Filter must engage the Baffle Filter interlock switch when installed. **If this switch is not actuated, the Fryer heating element will not energize.**
4. Replace and latch the Filter Access Cover. **IMPORTANT: Appliance will not operated unless the Cover is properly installed and secured.**



The Baffle Filter is constructed of very thin, stainless steel, sheet metal and has exposed edges. The user must use due diligence when handling this Filter to avoid possible injury. We recommend wearing heavy duty rubber gloves when handling and washing this Filter.

## 7-02.03. Electronic Air Cleaner (EAC) Cell Removal and Installation

1. Unlatch and lift the Filter Access Cover (not shown) up and off of the Hood.
2. The Electronic Air Cleaner (EAC) Cell **1** slides into the filter compartment. To remove, use the plastic handle and carefully pull it out, at a slight upward angle. **IMPORTANT: The Cell contains nine (9) fine ionizer wires and a large bank of thin collection plates (fins). When handling and cleaning this filter, use extreme care not to break the wires, or damage the collection fins. Doing so will diminish the effectiveness of the air cleaner, and possibly damage the power supply system.**

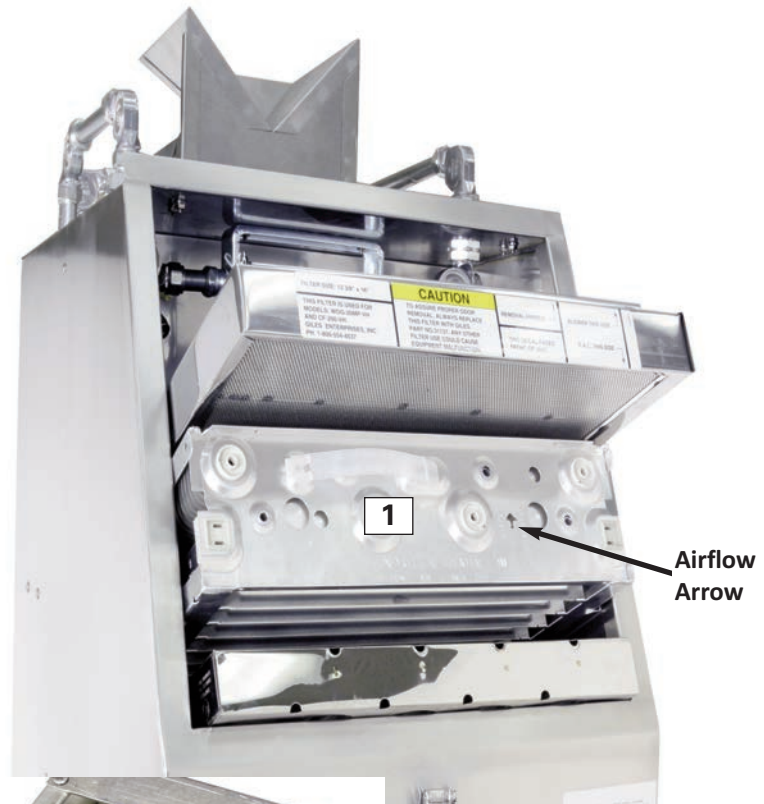

3. To replace Cell, align sides with the filter channels inside the compartment and slide it in until it stops. Ensure that the airflow arrow on the Cell points **UP**. The Cell fits into the Hood in one way only. An alignment pin on the rear wall prevents incorrect installation. If the Cell does not easily slide into position, **DO NOT** force it; check alignment and retry.  
The Cell's contact pad must make a good connection with the Contact Board inside the Hood. **If the connection is poor, the Fryer heating element may be disabled.**

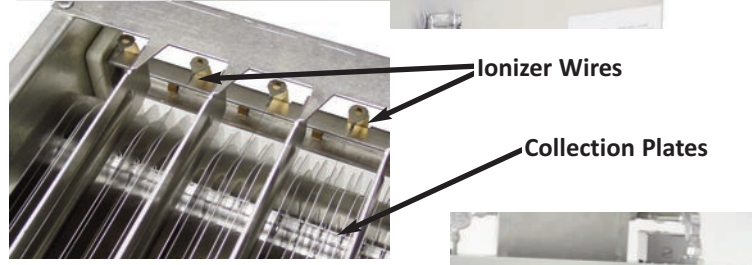

4. Replace and latch the Filter Access Cover. **IMPORTANT: Appliance will not operate unless the Cover is properly installed and secured.**

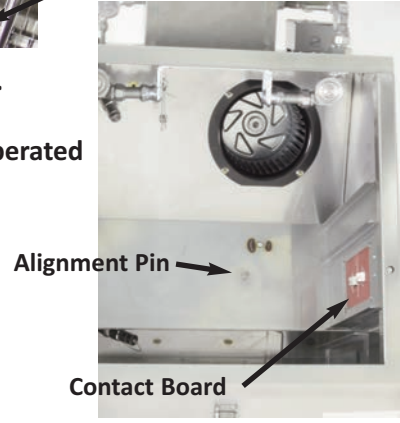

## 7-02.04. Charcoal Filter Removal and Installation

1. Unlatch and lift the Filter Access Cover (not shown) up and off of the Hood.
2. The Charcoal Filter **1** simply slides into the filter compartment. To remove, grasp it and carefully pull it out, at a slight upward angle.
3. To replace Filter, align sides with the filter channels inside the compartment and slide it in until it stops. Ensure that the Filter is positioned as shown by the indicator on the label.

When installed, the Filter must engage a Filter interlock switch on the rear wall. **If this switch is not actuated, the Fryer heating element will not energize.**

4. Replace and latch the Filter Access Cover. **IMPORTANT: Appliance will not operated unless the Cover is properly installed and secured.**

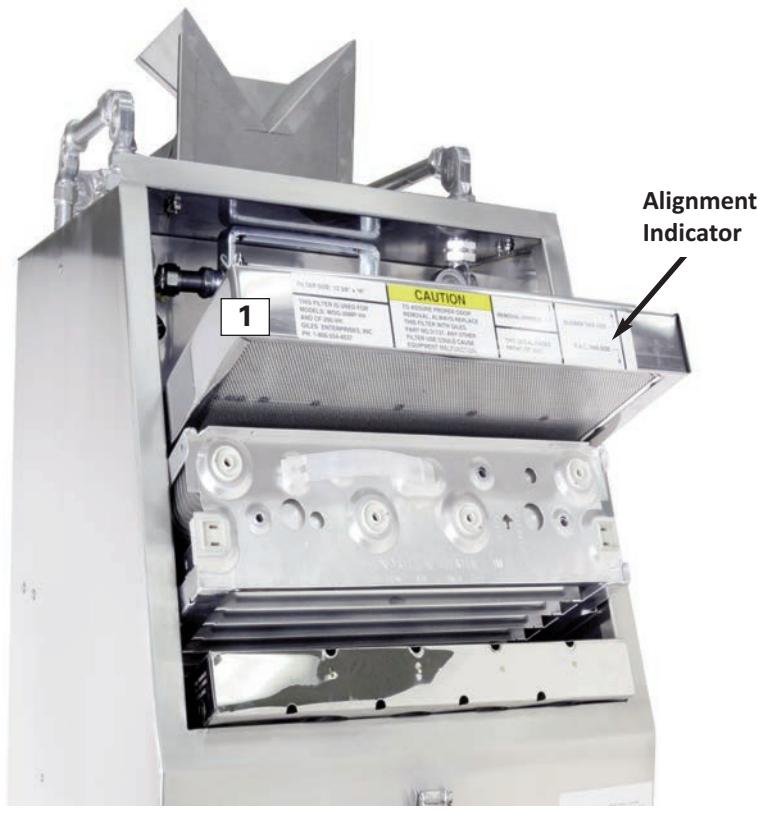

## 7-03. Filter Alarms

The following sections describe Filter System alarm conditions and corrective actions.

### 7-03.01. Baffle or Charcoal Filter Missing Alarm (constant tone signal)

If the Baffle or Charcoal Filter is missing, or not properly installed, the red Filter Missing Light **1** will turn on, and a continuous tone alarm signal will sound. While in this alarm state, the Fryer heating element is disabled and will not heat.

Check filter installation, remove and reinstall filters. See **Section 7-02.02 Baffle Filter Removal & Installation** and **Section 7-02.04, Charcoal Filter Removal & Installation**. Be sure that the filter is actuating the Filter Interlock Switch when installed.



### 7-03.02. Electronic Air Cleaner (EAC) Alarm (intermittent beeping tone signal)

Three LED indicator lights on the Control Panel display the status of the EAC Filter System.

**ON 1 ... WASH 2 ... CHECK 3** WASH and CHECK always turn on together when in alarm state.

- The **ON** light will be the only indicator illuminated when the EAC Cell is properly installed, and the system is powered and functioning normally.
- **EAC Cell missing or improperly installed:** On initial start-up, all three (ON-WASH-CHECK) indicators are **ON**. After approximately 2 minutes an intermittent (beeping) tone alarm signal sounds. While in this alarm state, the Fryer heating element is disabled and will not heat.



Be sure Cell is installed and seated properly, see **Section 7-02.03, EAC Cell Removal and Installation**. The contact pad must be making good connection with the Contact Board inside the Hood. Accumulation of grease film can cause poor connection; clean contacts if needed.

- **EAC Cell collection fins excessively dirty:** During cooking operations, the WASH-CHECK indicators turn **ON**. After approximately 2 minutes an intermittent (beeping) tone alarm signal sounds, and shortly thereafter the **HEAT** light turns **OFF**, or stops cycling **ON/OFF**, indicating the heating element is disabled. When the Cell has become too dirty to function any longer, the system will shutdown and disable the Fryer until the Cell is cleaned.
- **Other conditions causing EAC alarm: (May require qualified service technician assistance to correct)**
  - Too many ionizer wires broken, or missing from the Cell.
  - Too many fins bent and touching.
  - Internal electrical, or wiring, problems.
  - Faulty EAC power supply.
  - EAC Cell damaged or shorted out.



## 7-03.03. Clogged Filter Alarm (constant tone signal)

- During cooking operations or on initial start-up, a continuous tone alarm signal sounds. The Filter Missing light is not **ON** and the **HEAT** light turns **OFF**, or stops cycling **ON/OFF**, indicating the heating element has been disabled. This alarm is caused by a clogged filter, or other condition which has reduced airflow through the Hood to a level that is below the minimum for effective capture of the grease-laden vapor.
- **Clogged Charcoal Filter:** Check date when the Charcoal Filter was last replaced. This Filter is a one-use, consumable item and must be replaced periodically. Typical replacement cycle is every 30 to 40 days, depending on type of foods cooked and volume. **See Section 7-02.04, Charcoal Filter Removal and Installation.**  
**IMPORTANT: Never attempt to clean and reuse a Charcoal Filter! REPLACE ONLY** with Giles Charcoal Filter, P/N 31137.
- **Clogged Baffle Filter:** Check for signs of obstruction. Excessive accumulation of greasy film can slow the airflow. If excessively dirty wash the Filter, dry thoroughly and replace.
- **Dirty Fan Blades:** Inspect the blades of the Hood fan. Excessive grease build-up can reduce the fan efficiency thus slowing the airflow. It is advisable to have a service technician clean the Hood fan.
- Persistent Clogged Filter alarms require the attention of a qualified equipment service technician

## 7-04. Filter Cleaning

To maintain peak performance of the Ventless Hood, it is very important to clean and maintain the system Filters as described in the following sections.

### 7-04.01 Cleaning the Baffle Filter

- It is recommended that the Baffle Filter, typically, be cleaned daily.
- Remove Filter from Hood, see **Section 7-02.02 Baffle Filter Removal & Installation.** Wash in the sink using warm soapy water. A mild, biodegradable, degreaser may also be used. Rinse thoroughly using a hot water spray. The Baffle Filter can be washed in the dishwasher.
- Stand Filter up in a dish drainer on the edge with drain holes facing down to allow any trapped water to drain.
- Allow Filter to dry completely before replacing in Hood. **NEVER PLACE A WET FILTER INTO THE HOOD.**



 <b>WARNING</b>	
	Sharp edges Watch your fingers

The Baffle Filter is constructed of very thin, stainless steel, sheet metal. The edges of the baffles can cause cuts if mishandled. Always use extreme care when handling and cleaning this filter to avoid personal injury. Use of heavy-duty rubber gloves is recommended.

 <b>CAUTION</b>
--

- Operating the appliance with a wet filter could damage the Air Cleaning System, and void the factory warranty.

## 7-04.02 Cleaning the EAC Filter Cell

To maintain peak performance, the EAC Filter Cell **must** be cleaned daily, or as otherwise recommended. Failure to do so will eventually lead to filter system failure and will reduce Charcoal Filter life, leading to increased operating costs. Follow the procedure below for effective cleaning.

**IMPORTANT:** The EAC Cell is **NOT** designed to withstand washing in commercial dishwashers.

### CAUTION

- Avoid bending the Collection Fins or breaking the fine Ionizer Wires of the Filter Cell. Doing so will prevent the collecting cell from performing properly, and potentially void the factory warranty.
- After cleaning, never place the wet Cell into the Hood for operation; it must be completely dry. Doing so can damage the air cleaner power supply, and void the factory warranty.

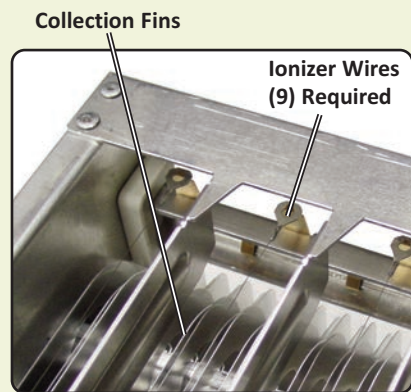

1. Add **64 ozs.** of a mild degreaser concentrate, such as **Simple Green** or **Clear Magic**, to the provided Soak Tank **1** ... add water to the fill line etched on the inside of the Tank's back and mix thoroughly.
2. Grasp the Contact Plate **2** and carefully lower the EAC Cell **3** into the mixed degreasing solution.
3. Allow the Cell to soak for 30 minutes. After that time, hold cell by the Contact Plate, agitate up and down in the solution several times to dislodge grease residue.
4. Carefully remove the Cell from the Soak Tank and rinse thoroughly in sink, using hot water spray.
5. Stand cell on end in dish drainer with Contact Plate up and allow it to air dry overnight. **Cell must be completely dry before using.**
6. Inspect the Cell for broken wires and bent fins. Broken wires need to be replaced promptly. If needed, bent fins may be gently straightened by hand.

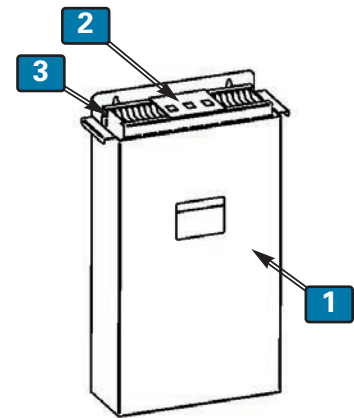

The degreasing solution can be used for up to 30 days, or until a greasy film is visible on top of the liquid. When soaking, always ensure that solution completely covers the cell ... add water if needed.

With proper care, cleaning, and handling, the EAC Cell is designed to provide years of service. It is important that it be cleaned as described above.

## 7-04.03. Charcoal Filter Replacement

The Charcoal Filter cannot be cleaned, or reused. It is a **one-use, consumable filter that must be periodically replaced**. The typical replacement cycle is every 30 to 40 days, depending on type of foods cooked and volume. See Section 7-02.04, Charcoal Filter Removal and Installation.

**IMPORTANT!! Never attempt to clean and reuse a Charcoal Filter!**  
**REPLACE ONLY** with Giles Charcoal Filter, P/N 31137.

**Failure to use Giles OEM replacement parts and filters may void the factory warranty.**

## 7-05. Ventless Hood Maintenance

The following Section describes periodic maintenance necessary to maintain long-term efficiency of the Hood system. A **Maintenance & Service Log** is provided in this manual.

### 7-05.01. Monthly Interlock Inspection

The WOG-20MP-VH Ventless Hood incorporates a system of interlock switches to ensure the unit will operate safely and effectively. Testing of the interlock system should be conducted MONTHLY in the following manner. Use the Log to record the completion of these inspections. If problems are detected, contact a qualified kitchen equipment service company to have the unit evaluated and repaired. To accurately assess function, perform these checks when the oil is cool.

1. **Baffle Filter Check:** Place the Power Switch in the **OFF** position. Remove the Filter Access Cover, then remove the Baffle Filter; replace and latch the Cover. Place the Power Switch in the **ON** position. The red **FILTER MISSING** light should turn **ON**, and a constant tone alarm should sound. Place the Selector Switch in the **COOK** position; the **HEAT** light should not turn on. Return the Power and Selector Switches to the **OFF** position. Reinstall Baffle Filter in the Hood.
2. **EAC Filter Check:** Remove the EAC Cell; replace and latch the Cover. Place the Power Switch in the **ON** position and the Selector Switch in the **OFF** position; all three (3) EAC Status lights should be **ON**. After approximately two (2) minutes; an intermittent, beeping tone alarm should sound. After the alarm starts, place the Selector Switch in the **COOK** position. The **HEAT** light should not turn on. Return the Power and Selector Switches to the **OFF** position. Reinstall the EAC.
3. **Charcoal Filter Check:** Remove the Charcoal Filter; replace and latch the Cover. Place the Power Switch in the **ON** position. The red **FILTER MISSING** light should turn **ON**, and a constant tone alarm should sound. Place the Selector Switch in the **COOK** position; the **HEAT** light should not turn on. Return the Power and Selector Switches to the **OFF** position. Reinstall Charcoal Filter in the Hood.
4. **Filter Clogged Check:** Cut a piece of filter paper, or other suitable material, to a size that completely covers the area of the Baffle Filter. Place the Power Switch in the **ON** position and the Selector Switch in the **COOK** position; **HEAT** light turns on and Fryer begins heating. Place the cut material over the filter area; suction of the Hood will hold it. Within a few seconds, a constant tone alarm should sound and the **HEAT** light should turn off. Return switches to the **OFF** position and remove the test blockage.

## 7-05.02. Quarterly Hood Cleaning

Turn **OFF** supply power to the unit. Remove the Filter Cover and all Filters from the hood. Use a mild degreaser and sanitized towels to clean the entire Hood plenum and blower section. This internal Hood cleaning must be performed every three (3) months.

## 7-05.03. Semi-Annual Fire Suppression System

Servicing and maintenance of the fire suppression system must be conducted by a qualified fire protection equipment service company, having credentials acceptable the local authorities having jurisdiction (AHJ). As a minimum, field inspection of the Fire Suppression System shall be performed semi-annually by a certified fire protection equipment company. Such inspection shall consist of the following.

Place Locking Bar on the extinguisher system when servicing.

1. Remove charging cartridge, inspect gasket for cuts and elasticity, coat gasket with extreme temperature grease and reinstall. See **Section 2-08. Fusible Link and Gas Cartridge Locations**
2. Remove tank, verify suppressant chemical is at proper level, clean and coat O-ring with extreme temperature grease and reinstall. See **Section 2-09. Fire Extinguisher Nozzle and Tank Locations**
3. Check discharge nozzles for signs of grease buildup and clean. Inspect condition of blow-off caps; replace if missing or damaged.
4. Inspect remote manual activation station for function and wear.
5. Install test link; cut to test automatic actuation function.
6. Clean and inspect fusible links. See **Section 2-08. Fusible Link and Gas Cartridge Locations**
7. Inspect wire rope for wear at pulleys and detectors; replace as needed.
8. Tag the system; record maintenance date and log the inspection in a permanent file.

## 7-05.04. Annual Fire Suppression System

Same as Semi-Annual, except that all fusible links must be replaced. See **Section 2-08. Fusible Link and Gas Cartridge Locations**

## 7-05.05. 12 Year Suppression System

Same as Semi-annual and Annual except shall include:

1. Replacement of the R-102 wet chemical fire suppressant.
2. Hydrostatic testing of the suppressant chemical tank and gas cartridge.
3. Flow testing of the regulator.

## 7-05.06. Maintenance and Service Log

Check				Initial/Date				Check				Initial/Date					
✓	✓	✓	✓					<i>RGS</i>	<i>11/5/10</i>	1	2	3	4				
1	2	3	4							1	2	3	4				
1	2	3	4	5						1	2	3	4	5			
1	2	3	4							1	2	3	4				
1	2	3	4							1	2	3	4				
1	2	3	4	5	6*					1	2	3	4	5	6*		
1	2	3	4							1	2	3	4				
1	2	3	4							1	2	3	4				
1	2	3	4	5						1	2	3	4	5			
1	2	3	4							1	2	3	4				
1	2	3	4							1	2	3	4				
1	2	3	4	5	6*	7*				1	2	3	4	5	6*	7*	
1	2	3	4							1	2	3	4				
1	2	3	4							1	2	3	4				
1	2	3	4	5						1	2	3	4	5			
1	2	3	4							1	2	3	4				
1	2	3	4							1	2	3	4				
1	2	3	4	5	6*					1	2	3	4	5	6*		
1	2	3	4							1	2	3	4				
1	2	3	4							1	2	3	4				
1	2	3	4	5						1	2	3	4	5			
1	2	3	4							1	2	3	4				
1	2	3	4							1	2	3	4				
1	2	3	4	5	6*	7*				1	2	3	4	5	6*	7*	
1	2	3	4							1	2	3	4				
1	2	3	4							1	2	3	4				
1	2	3	4	5						1	2	3	4	5			
1	2	3	4							1	2	3	4				
1	2	3	4	5	6*					1	2	3	4	5	6*		
1	2	3	4							1	2	3	4				
1	2	3	4							1	2	3	4				
1	2	3	4	5						1	2	3	4	5			
1	2	3	4							1	2	3	4				
1	2	3	4	5	6*	7*				1	2	3	4	5	6*	7*	

1	Baffle Filter Check
4	Filter Clogged Check
7	Annual Fire System Insp

2	EAC Filter Check
5	Quarterly Cleaning

3	Charcoal Filter Check
6	Semi-annual Fire System Insp

\* Inspection performed by certified fire equipment service company.

## 8. Troubleshooting

This section describes some basic troubleshooting procedures for Giles WOG-20MP & WOG-20MP-VH Model Electric Fryers. Some very basic operational issues may be corrected by the user, however in most cases, troubleshooting should be performed only by qualified service technicians.

<b>8-01. Temperature Control System</b>		
<b>Problem</b>	<b>Probable Cause</b>	<b>Corrective Action</b>
<b>APPLIANCE WILL NOT TURN ON:</b> <ul style="list-style-type: none"> <li>• Power Light not <b>ON</b></li> <li>• VH Model - Hood Fan does not run</li> </ul>	A. Not connected to proper power source	Connect unit to proper power supply
	B. Blown fuse or tripped breaker in electrical supply panel	Check electrical panel, replace fuse or reset breaker
	C. Blown fuse in unit (inside lower cabinet) or faulty fuse holder	Check/replace fuses. Check fuse holders behind Fryer Control Panel
	D. Hood Filter Cover not closed & latched properly ( <b>VH Model</b> )	Close Cover properly; pin on right edge must engage interlock switch
	E. Faulty Power Switch	Check/replace Power Switch
	F. ( <b>VH Model</b> ) Fire Extinguisher System not armed	Contact Ansul service company
	G. ( <b>VH Model w/ILS</b> ) PUSH TO START button not pressed & held for 5 secs	Press & hold button for at least 5 secs
	H. ( <b>VH Model</b> ) EAC Cleaning Timer has expired; red <b>CHANGE NOW</b> Light is <b>ON</b>	Remove Cover, clean EAC Cell, or press <b>SNOOZE</b> button to continue operation for 2 hours
<b>FRYER WILL NOT HEAT:</b> <ul style="list-style-type: none"> <li>• Power Light is <b>ON</b></li> <li>• Heat Light is <b>OFF</b></li> </ul>	A. Selector Switch is not in the <b>COOK</b> position	Place Selector Switch in <b>COOK</b> position
<b>FRYER WILL NOT HEAT:</b> <ul style="list-style-type: none"> <li>• Power Light is <b>ON</b></li> <li>• Selector Switch is in <b>COOK</b> position</li> <li>• Heat Light is <b>OFF</b></li> </ul>	A. Thermostat setpoint is below actual oil temperature	Reset the temperature, or if changing to a lower temp setting, oil must cool to new temp
	B. Drain Valve is <b>OPEN</b> ; alarm sounding	Close valve fully, reset alarm
	C. Digital Thermostat is faulty	Check/replace Thermostat
	D. Variable temperature sensor faulty	Check wiring; replace sensor
	F. Contactor is faulty	Check/replace Contactor
	G. Selector Switch is faulty	Check/replace Switch

**8.01 Temperature Control System (continued)**

<b>Problem</b>	<b>Probable Cause</b>	<b>Corrective Action</b>
<b>FRYER WILL NOT HEAT: (VH Model Only)</b> <ul style="list-style-type: none"> <li>• Power Light is <b>ON</b></li> <li>• Selector Switch is in <b>COOK</b> position</li> <li>• Continuous tone alarm sounding</li> <li>• <b>FILTER MISSING</b> light is <b>ON</b></li> </ul>	A. Baffle Filter missing	Check, install Baffle Filter
	B. Baffle Filter misaligned	Check, reinstall, or properly align Baffle Filter
	C. Charcoal Filter missing or misaligned	Check, reinstall, or properly align Charcoal Filter
<b>FRYER WILL NOT HEAT: (VH Model Only)</b> <ul style="list-style-type: none"> <li>• Power Light is <b>ON</b></li> <li>• Selector Switch is in <b>COOK</b> position</li> <li>• Heat Light is not <b>ON</b></li> <li>• Beeping tone alarm sounding</li> <li>• EAC Status <b>WASH/CHECK</b> lights are <b>ON</b></li> </ul>	A. EAC Cell is excessively dirty	Clean the EAC Cell
	B. EAC Cell has bent fins, or shorted	Repair EAC Cell
	C. EAC Cell has too many broken ionizer wires	Replace ionizer wires on Cell
	D. Poor connection with Contact Board; dirty or damaged	Clean contacts, or replace board
	E. EAC Power Supply is faulty	Replace Power Supply
	F. EAC Shutdown Module is faulty	Replace Module
	G. EAC Cell is missing	Install or reinstall EAC Cell
<b>FRYER WILL NOT HEAT:</b> <ul style="list-style-type: none"> <li>• Power Light is <b>ON</b></li> <li>• Selector Switch is in <b>COOK</b> position</li> <li>• High Limit Light is not <b>ON</b></li> </ul>	A. Power surge	Cycle Power Switch <b>OFF</b> for approx 5 secs, return to <b>ON</b>
	B. Low oil level	Check level, add oil as needed
	C. Contactor is sticking	Check/replace Contactor
	D. High Limit Safety Board is faulty	Check/replace High Limit Board
	E. High Limit Sensor is faulty	Check/replace sensor
	E. Digital Thermostat is faulty	Check/replace Thermostat
<b>FRYER WILL NOT HEAT: (VH Model Only)</b> <ul style="list-style-type: none"> <li>• Power Light is <b>ON</b></li> <li>• Selector Switch is in <b>COOK</b> position</li> <li>• Heat Light is not <b>ON</b></li> <li>• Constant tone alarm sounding</li> </ul>	A. Charcoal Filter clogged	Replace Charcoal Filter
	B. Vacuum Switch requires adjustment, or is faulty	Adjust Switch, replace if needed
	C. Vacuum lines clogged or kinked	Check tubing clean, or remove kinks
	D. Fan running too slow	Check voltage
	E. Fan clogged with grease film	Clean fan

## 8.01 Temperature Control System (continued)

Problem	Probable Cause	Corrective Action
<b>FRYER HEATS SLOWLY:</b> <ul style="list-style-type: none"> <li>• Slow heat recovery</li> <li>• Heat Light remains <b>ON</b> constantly</li> </ul>	A. Improper cooking procedures	Consult Operations Manual for proper procedures
	B. Heating element faulty	Check/replace faulty element
	C. Contactor failing	Check/replace Contactor
	D. Loose wiring	Check/repair wiring
	E. Low voltage coming to Fryer	Check/repair supply power
<b>FRYER HEATS SLOWLY</b> <ul style="list-style-type: none"> <li>• Short cycling, Heat Light turning <b>ON &amp; OFF continuously</b></li> </ul>	A. Low voltage coming to Fryer	Check/repair supply power
	B. Variable temp sensor too close to heating element	Correct sensor position
	C. Digital Thermostat is faulty	Replace Thermostat
<b>OIL TEMPERATURE ERRATIC:</b>	A. Faulty temperature sensor	Replace probe
	B. Contactor is failing	Replace Contactor
	C. Digital Thermostat is faulty	Replace Thermostat
	D. Loose wiring	Check/repair wiring
<b>OIL SMOKING:</b>	A. Oil has broken-down ... old	Change oil in Fryer
	B. Cooking temperature too high	Check temperature setpoint, adjust
	C. Dirty Heating Element	Perform Boil-out, clean element
	D. Element failure	Check/replace element
	E. Improper supply voltage	Verify incoming power
	F. Low oil level	Keep oil level at the <b>FULL</b> mark

<b>8.02 Oil Filtration System</b>		
<b>Problem</b>	<b>Probable Cause</b>	<b>Corrective Action</b>
<b>OIL NOT PUMPING BACK TO FRY POT:</b>	A. Selector Switch not in <b>PUMP</b> position	Place Switch in proper position
	B. Air leak in the system plumbing (hoses, fittings, connector, filter pan)	Check & eliminate air leak, be sure quick-disconnect is secure
	C. Pump motor faulty	Check/replace Motor
	D. Oil Pump clogged, or damaged	Check/repair Pump
	E. Excessive sludge in Filter Pan	Clean Filter Pan, replace media
	F. Filter Pan not assembled properly	Assemble correctly
	G. Oil is Filter Pan below 200°F	Remove cold oil from Filter Pan
<b>OIL PUMP LOCKED UP</b>	A. Boil-out solution has been run through Filter Pump	Disassemble Pump head, clean & re-oil
	B. Oil allowed to sit in Pump too long	Run clean, hot, oil through Pump

## 9. Parts List

This section lists various parts that are available for field replacement on WOG-20MP and WOG-20MP-VH Fryers.

### 9-01. Parts Ordering and Service Information

If assistance or repairs are needed, please contact a nearby Giles Manufacturer’s Representative to locate a factory-authorized service agent in your area, or contact Giles Technical Support at the numbers shown below:

#### IN THE UNITED STATES or CANADA

Call **800.554.4537** between 8:00AM - 5:00PM Central Time and follow the recorded prompts. During other than normal business hours, please call **800.554.4537** and follow the prompts to reach Technical Support.

#### IN ALL OTHER COUNTRIES

Call **334.272.1457** between 8:00AM - 5:00PM Central Time and follow the recorded prompts. During other than normal business hours, please call **334.272.1457** and follow the prompts to reach Technical Support.

#### INTERNET

Visit our website [www.gfse.com](http://www.gfse.com), or email [services@gfse.com](mailto:services@gfse.com).

The goal of the Giles team is to provide the highest possible quality of service and assistance. To help us accomplish this, please have following information readily available when calling. The area below may be helpful in recording information for use as a quick reference.

**Model:** \_\_\_\_\_  
**Serial Number:** \_\_\_\_\_  
**Voltage:** \_\_\_\_\_ **Phase:** \_\_\_\_\_

The information can be found on the Serial Label located on the rear panel and inside the Fryer cabinet (or on the Hood Header for VH Models)

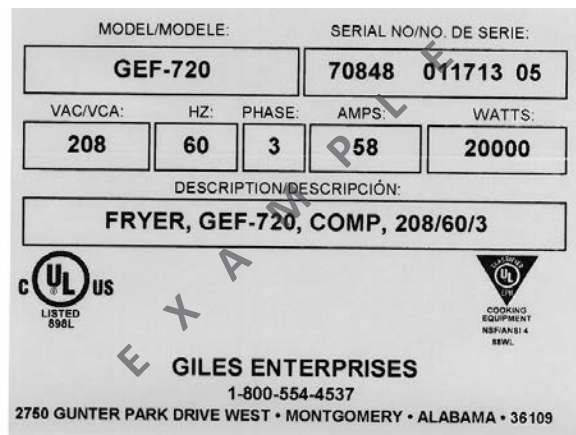

## 9-02. Control Panel



\* Ventless Hood (VH) Model only

# Parts List

# Model: WOG-20MP & WOG-20MP-VH



## 9-02. Parts List for Control Panel

Item	Part Number	Qty	Description
*1	24209	1	LED, AIR FILTER, EAC
2	23275	1	SWITCH, TOGGLE, ON-OFF, 2PL, 15A, 250V
3	20484	1	CONTROLLER, TEMP, WATLOW CV, 0-375F
4	23250	1	SWITCH, TOGGLE, ON-OFF, 1PL, 15A, 250V
5	24240	1	TIMER, 30-MIN, MECHANICAL
6	23225	1	SWITCH, TOGGLE, ON-OFF-ON, 1PL, 15A, 250V
7	20398	1	LIGHT, INDICATOR, GREEN, 250V
8	20399	1	LIGHT, INDICATOR, ORANGE, 250V
9	20402	2	LIGHT, INDICATOR, RED, 250V
*10	20694	1	PILOT LIGHT, YELLOW, EAC TIMER
*11	20693	1	PILOT LIGHT, RED, EAC TIMER
*12	20692	1	SWITCH, MOMENTARY, PUSH-BUTTON

\* Ventless Hood (VH) Model only

9-03. Front Header

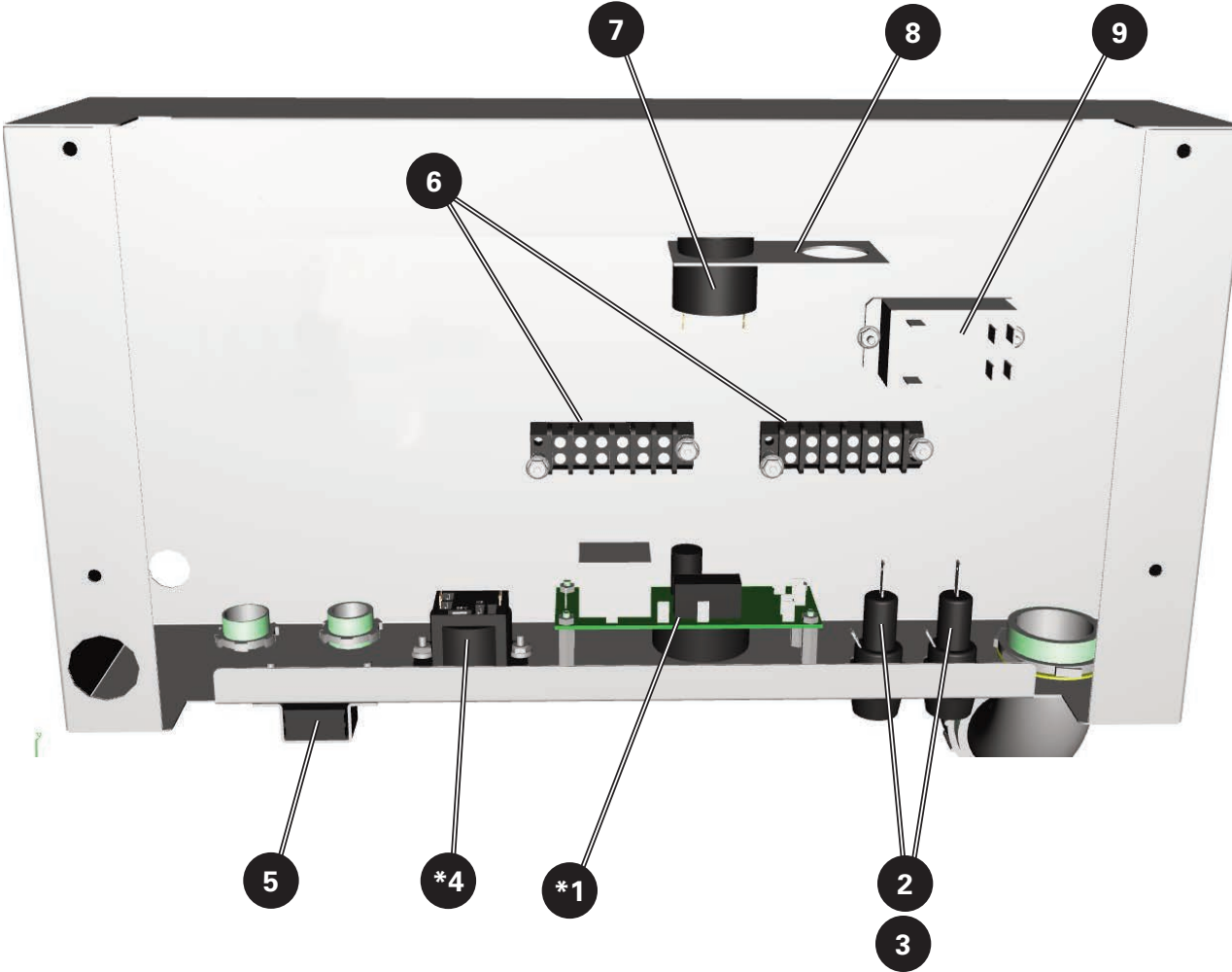

\* Ventless Hood (VH) Model only

# Parts List

# Model: WOG-20MP & WOG-20MP-VH



## 9-03. Parts List for Front Header

Item	Part Number	Qty	Description
*1	20572-R	1	EAC TIMER BOARD, REPLACEMENT
2	21950	2	HOLDER, FUSE, 300V, 15A, SC 0 TO 15
3	21900	2	FUSE, 15-AMP, SC-15
*4	21203	1	RELAY, SPST-NO, 240V
5	40850	1	CATCH, MAGNETIC
6	23751	2	TERMINAL BLOCK
7	23782	1	SONALERT, CONTINUOUS TONE, 250V
8	32043	1	BRACKET, SONALERT
9	21417	1	RELAY, POWER SWITCH, 30A/2.5HP, 240V

\* Ventless Hood (VH) Model only

9-04. Front Lower Cabinet

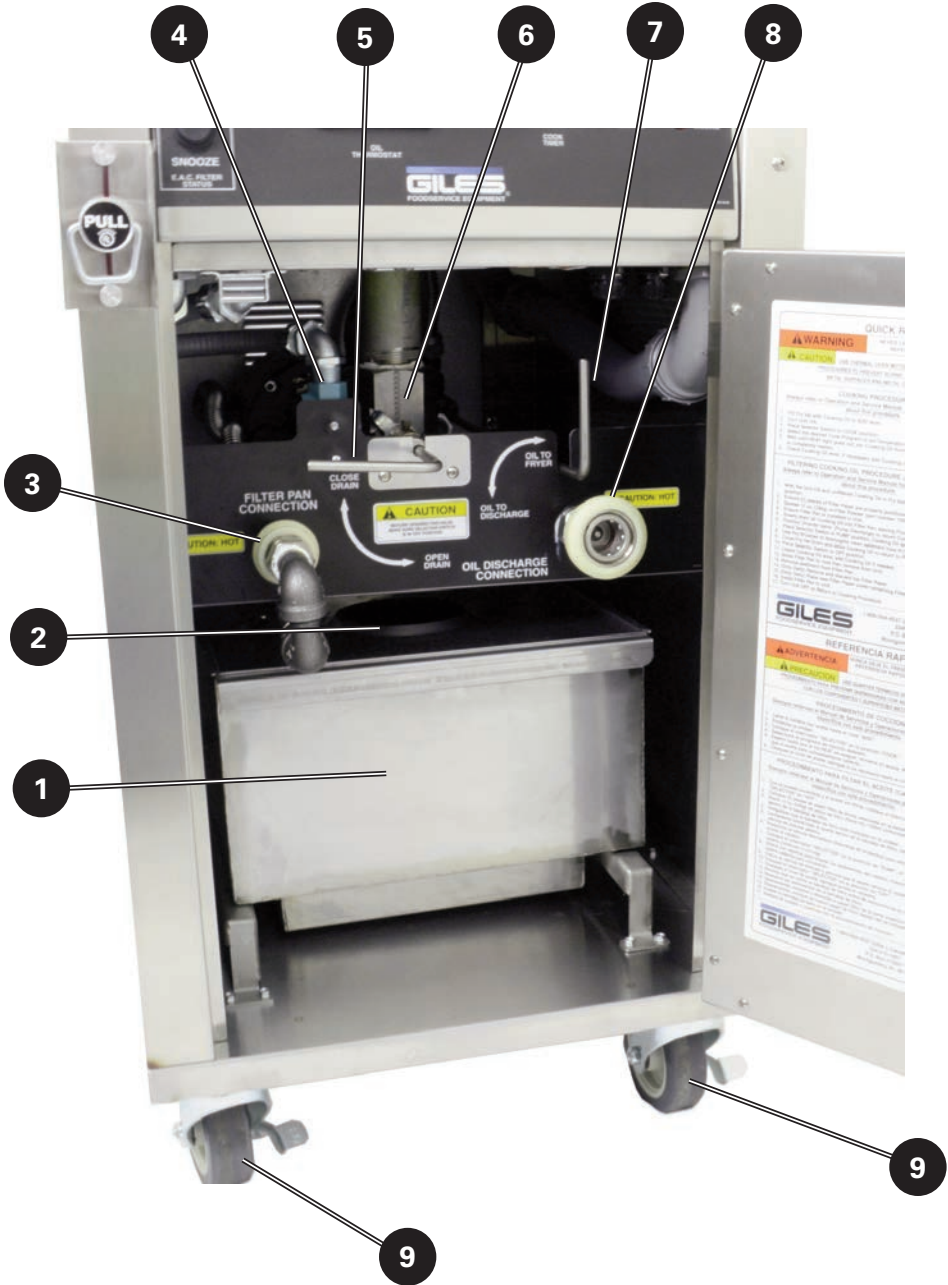

\* Not shown

# Parts List

# Model: WOG-20MP & WOG-20MP-VH



## 9-04. Parts List for Front Lower Cabinet

Item	Part Number	Qty	Description
1	96163	1	FILTER PAN ASSEMBLY, COMPLETE
2	96099	1	FILTER PAN COVER
3	41900	1	COUPLING, QUICK-DISCONNECT, FEMALE, 1/2" (FILTER PAN)
4	21157	1	SWITCH, LIMIT, 15A, 250V (DRAIN)
5	96087	1	DRAIN VALVE HANDLE ASSEMBLY
6	45876	1	VALVE, DRAIN, 1-1/2 NPT
7	96089	1	DIVERTER VALVE HANDLE ASSEMBLY
8	41699	1	COUPLING, QUICK-DISCONNECT, FEMALE (OIL DISCHARGE)
9	40700	2	CASTER, 5", SWIVEL, W/BRAKE, PLATE MOUNT (FRONT)

\* Not shown

9-05. Rear Lower Cabinet

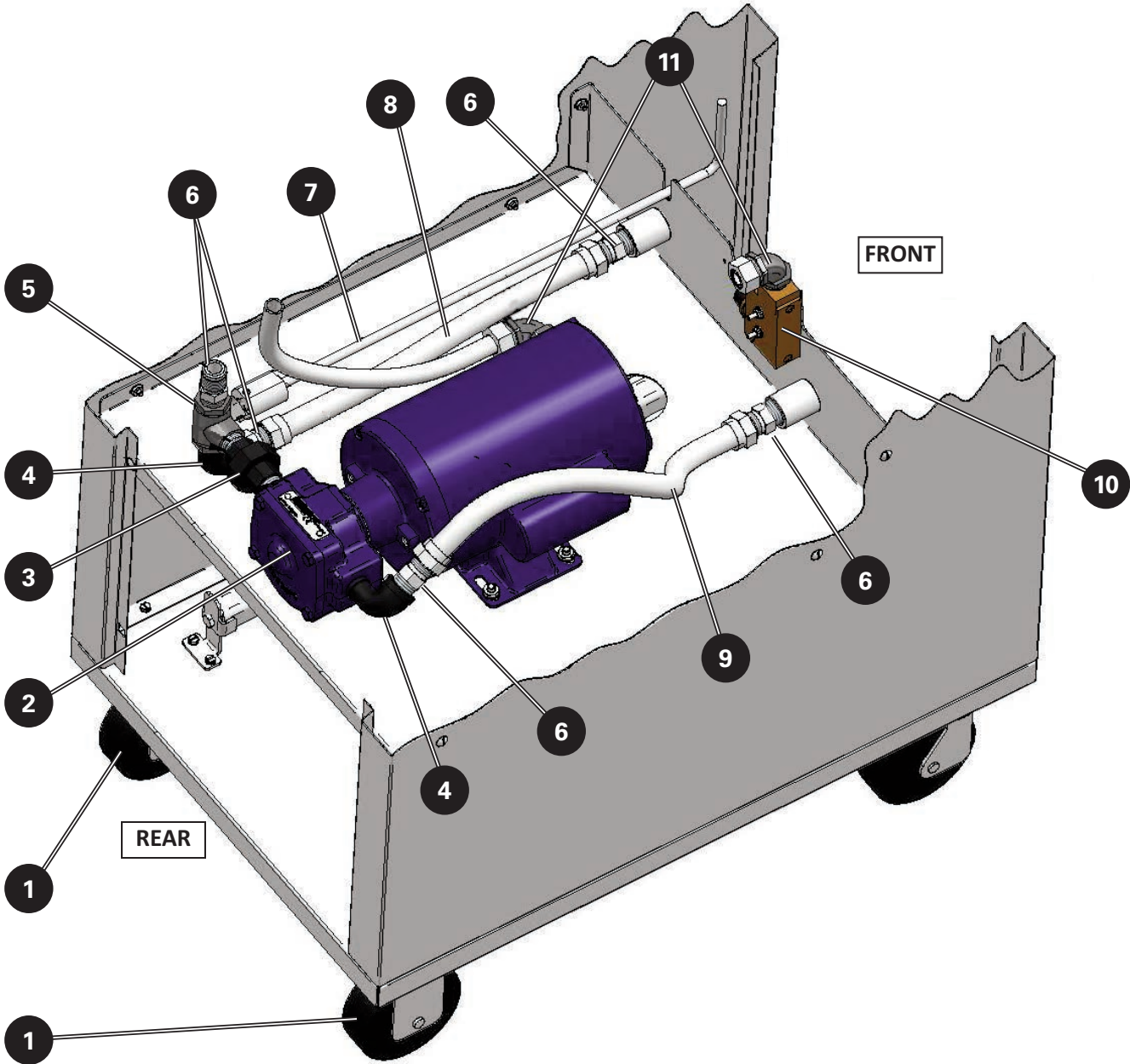

# Parts List

# Model: WOG-20MP & WOG-20MP-VH



## 9-05. Parts List for Rear Lower Cabinet

Item	Part Number	Qty	Description
1	40650	2	CASTER, 5", RIGID, PLATE MOUNT (REAR)
2	71754	1	PUMP & MOTOR ASSY, 1/2-HP, 8-GPM
3	45575	1	UNION, 1/2", BLACK PIPE
4	42250	2	STREET ELL, 1/2", 90°, BLACK PIPE
5	45755	1	VALVE, 3-WAY, 1/2NPT, NICKEL PLATED
6	40889	5	ADAPTOR, 1/2-COMPRESS TO 1/2-NPT
7	96089	1	DIVERTER VALVE HANDLE ASSEMBLY
8	40909	1	HOSE, CORRUGATED, SS, 1/2 ID X 15"
9	40907	1	HOSE, CORRUGATED, SS, 1/2 ID X 18"
10	21157	1	SWITCH, LIMIT, 15A, 250V (DRAIN)
11	20950	2	CONNECTOR, CONDUIT, 3/8", LQ TT, 90°

9-06. Rear Top Header (Cabinet), WOG-20MP

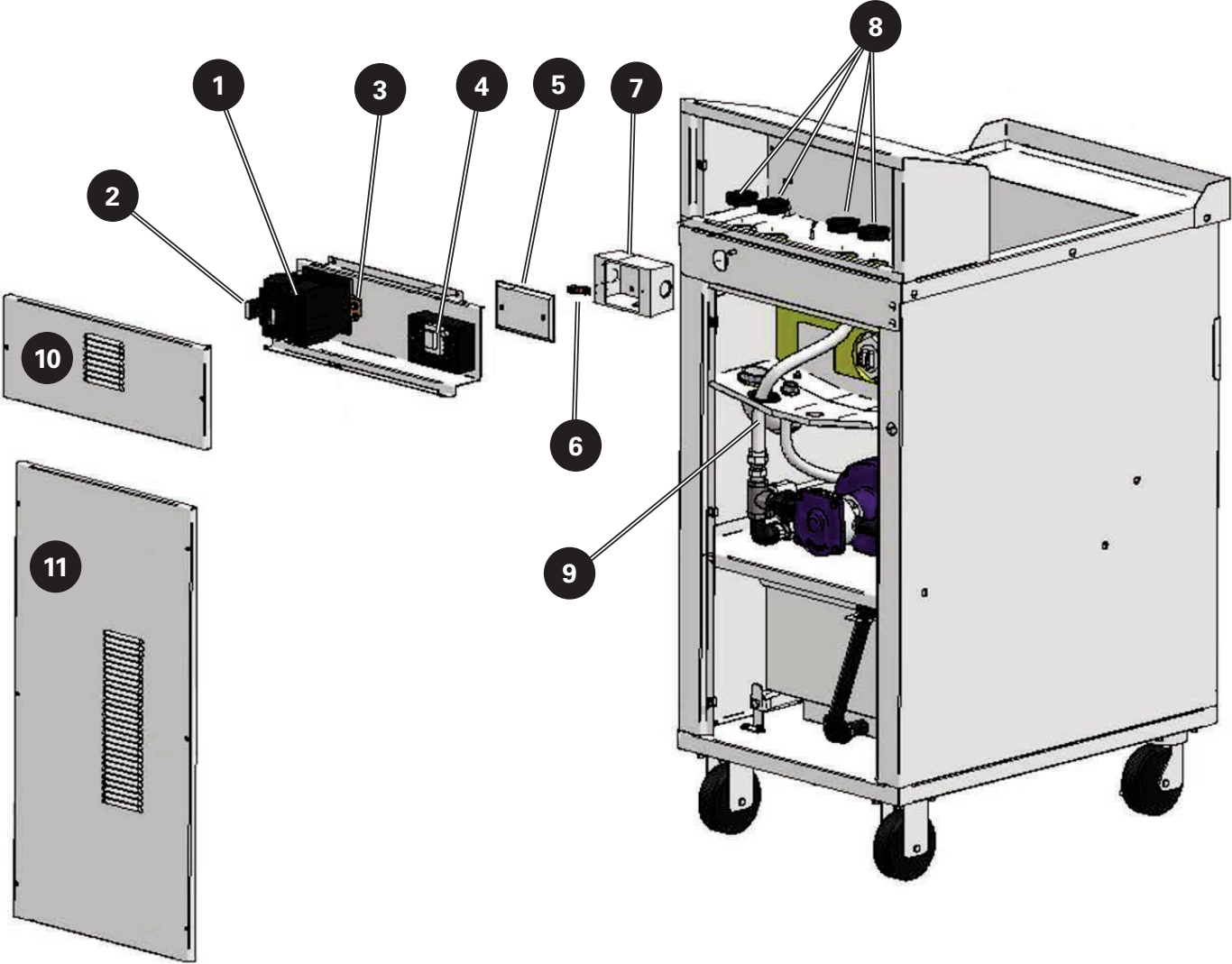

# Parts List

# Model: WOG-20MP & WOG-20MP-VH



## 9-06. Parts List for Rear Top Header, WOG-20MP

Item	Part Number	Qty	Description
1	21366	2	CONTACTOR, 3-POLE, 40A, 208V COIL
1	20686	2	CONTACTOR, 3-POLE, 40A, 240V COIL
2	21205	2	RC SUPPRESSOR, 40A
3	36666	1	DIN RAIL, 5.28-IN
4	23754	1	THERMOSTAT, HI-LIMIT SAFETY, 425-DEG, 208-240V
5	20800	1	SERVICE BOX COVER
6	24221	1	GROUND LUG
7	30107	1	SERVICE BOX
8	40201	4	BUSHING, 1-3/4 HOLE, SNAP-IN
9	40907	1	CORRUGATED HOSE, 18-IN, SS, W/NUTS (VAT FILL)
10	96219	1	PANEL, TOP HEADER BACK
11	96107	1	PANEL, CABINET BACK

9-07. Rear Component Assembly, WOG-20MP-VH

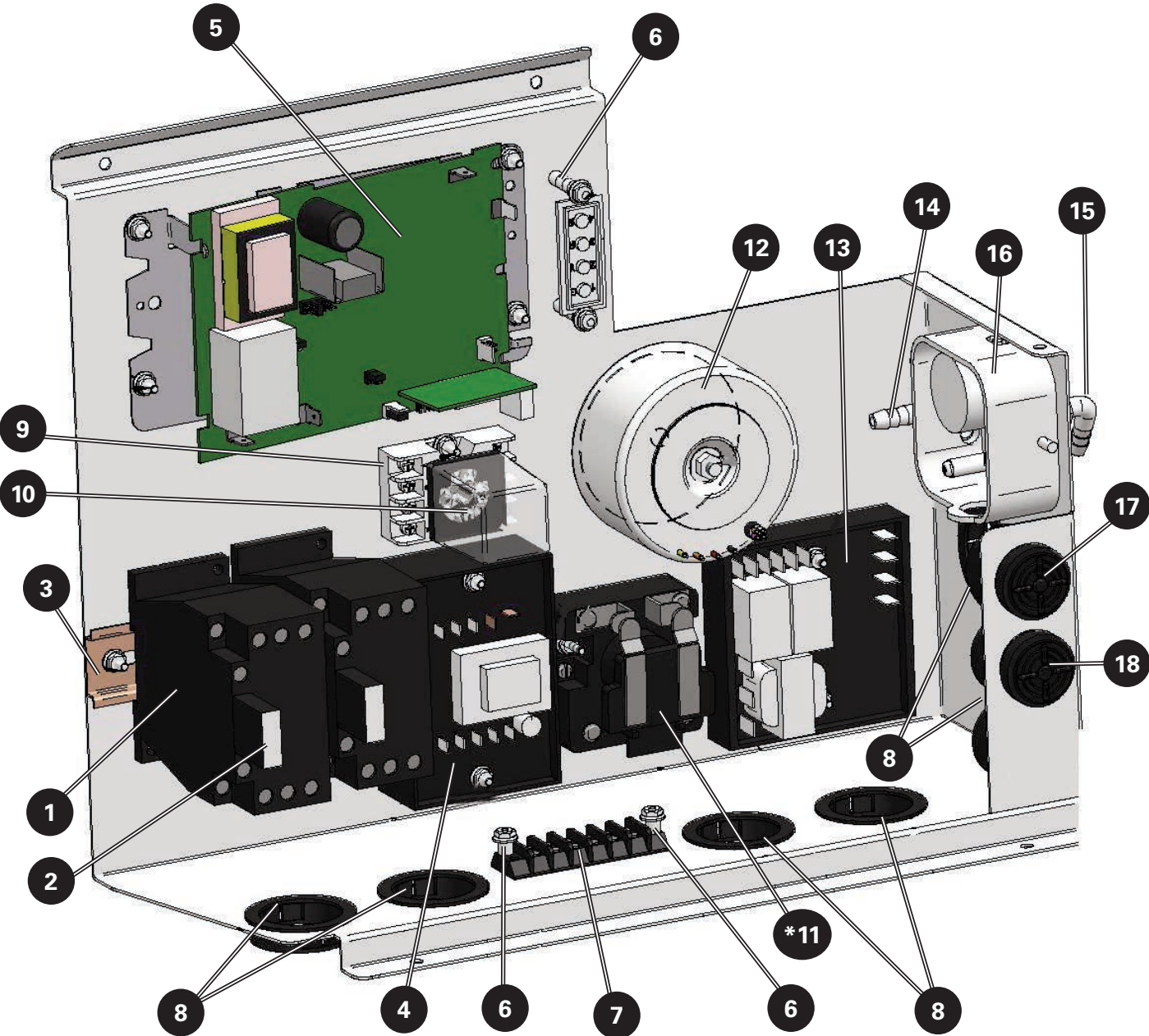

\* ILS Version ONLY

# Parts List

# Model: WOG-20MP & WOG-20MP-VH

## 9-07. Parts List for Rear Component Assembly, WOG-20MP-VH

Item	Part Number	Qty	Description
1	21366	2	CONTACTOR, 3-POLE, 40A, 208V COIL
1	20686	2	CONTACTOR, 3-POLE, 40A, 240V COIL
2	21205	2	RC SUPPRESSOR, 40A
3	36666	1	DIN RAIL, 5.28-IN
4	23754	1	THERMOSTAT, HI-LIMIT SAFETY, 425-DEG, 208-240V
5	21296	1	POWER PACK ASSEMBLY, W/DRVR BRD & TERM BLK, 120V
6	10152	8	SPACER, #6 X 1/4, PLASTIC
7	23751	1	TERMINAL BLOCK, 6-POLE, 250V, 15A
8	40201	6	BUSHING, 1-3/4 HOLE, SNAP-IN
9	21101	1	SOCKET, RELAY, 8 PIN, 300V, 10A
10	21102	1	RELAY, 8 PIN, 240V, 10A
*11	21191	1	RELAY, 2-POLE, 30A, 208V (ILS Version ONLY)
*11	21174	1	RELAY, 2-POLE, 30A, 240V (ILS Version ONLY)
12	21337	1	TRANSFORMER, 230VAC-to-115VAC @.86A, TRIAD
13	23776	1	ALARM/SHUTDOWN MODULE, E.A.C. FILTER
14	40877	1	FITTING, 1/4 BARBED, 90-EL, NYLON, 1/8 NPT
15	40880	1	FITTING, 1/4 BARBED, 90-EL, NYLON, 1/4 NPT
16	20390	1	VACUUM SWITCH, 0.16 -to- 1.20-IN WC
17	23782	1	SONALERT, CONTINUOUS TONE, 250V
18	22950	1	SONALERT, INTERMITTENT TONE, 250V

\* ILS Version ONLY

9-08. Hood Cabinet Rear, WOG-20MP-VH

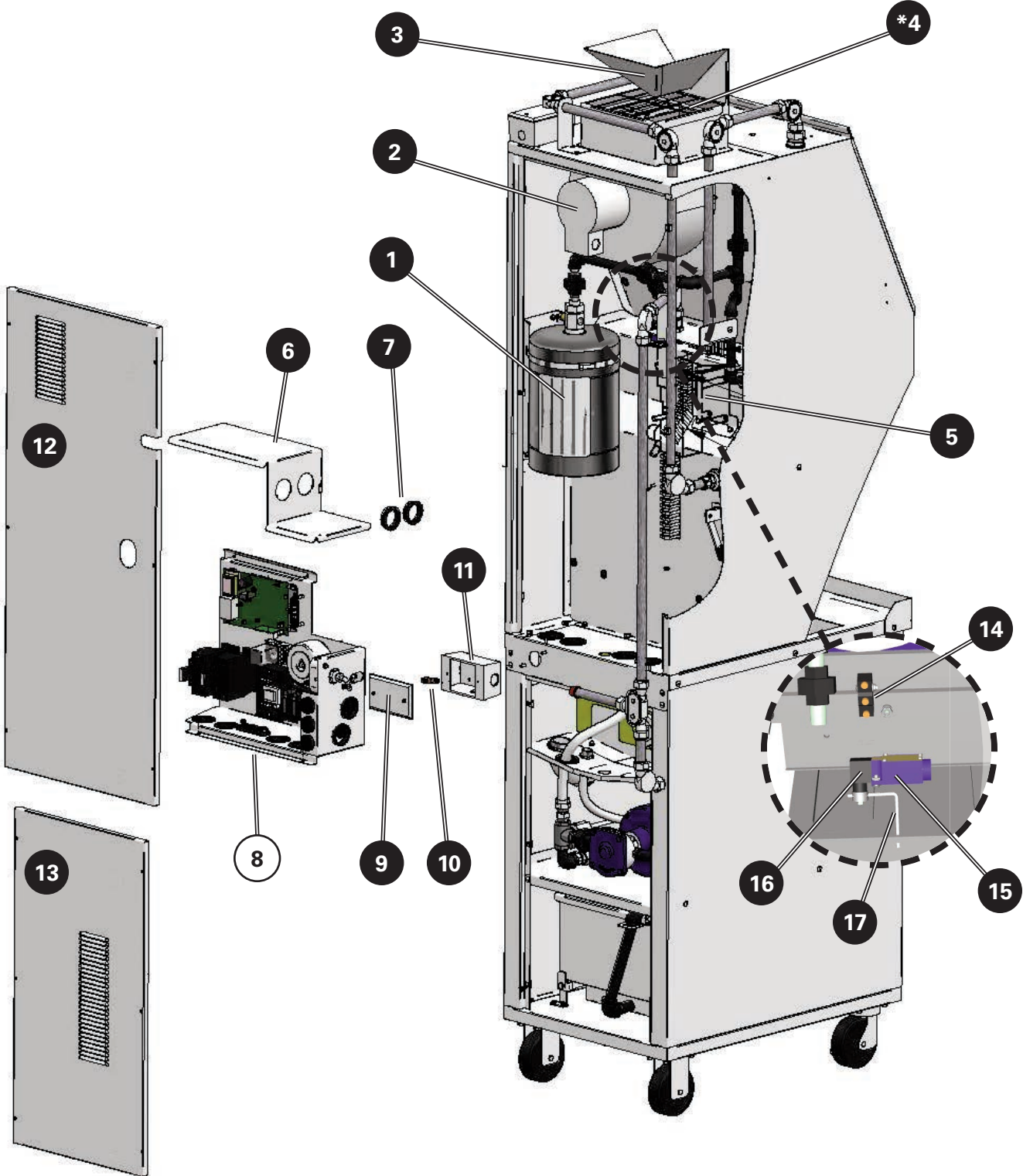

\* Not Shown

# Parts List

# Model: WOG-20MP & WOG-20MP-VH

## 9-08. Parts List for Hood Cabinet Rear, WOG-20MP-VH

Item	Part Number	Qty	Description
1	39272	1	TANK, ANSUL, 1.5-GAL
2	34619	1	BLOWER ASSEMBLY
3	92382	1	DAMPER COVER / 3-WAY DIVERTER
*4	46650	1	FIRE DAMPER, 8 X 8, 285-DEG
5	40132	1	RELEASE MECHANISM, ANSUL AUTOMAN
6	96083	1	COMPONENT COVER
7	40201	2	BUSHING, 1-3/4 HOLE, SNAP-IN
8	96194	1	COMPONENT ASSEMBLY (SEE SECTION 9-07)
9	20800	1	SERVICE BOX COVER
10	24221	1	GROUND LUG
11	30107	1	SERVICE BOX
12	96108	1	PANEL, HOOD BACK
13	96107	1	PANEL, CABINET BACK
14	24237	1	SWITCH, PLUNGER, 250V, 15A (CHARCOAL FILTER INTLK)
15	21183	1	SWITCH BODY, LEVER ACTION, 240V, 30A (BAFFLE FILTER INTLK)
16	21184	1	SWITCH HEAD, LEVER ACTION (BAFFLE FILTER INTLK)
17	30952	1	SWITCH LEVER, FORMED (BAFFLE FILTER INTLK)

\* Not Shown

9-09. Cooking Vat

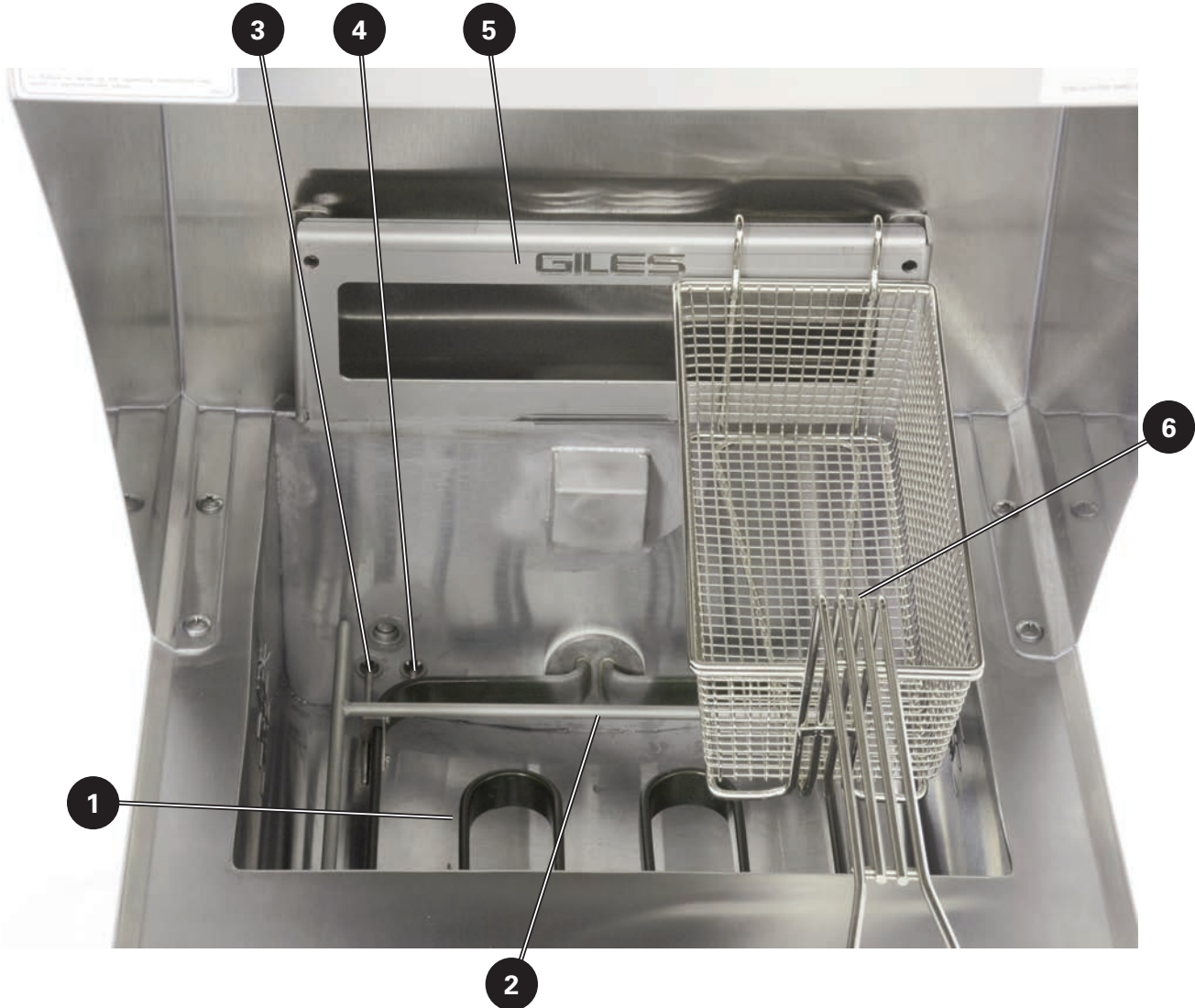

# Parts List

# Model: WOG-20MP & WOG-20MP-VH



## 9-09. Parts List for Cooking Vat

Item	Part Number	Qty	Description
1	23773	1	ELEMENT, FIREBAR, 6000W, 208V
1	23768	1	ELEMENT, FIREBAR, 6000W, 240V
2	31787	1	BASKET RACK
3	24222	1	THERMOCOUPLE, J-TYPE, 7-IN, BENT, GROUNDED
4	23909	1	THERMOCOUPLE, J-TYPE, 3-IN, GROUNDED
5	96693	1	BASKET HANGER
6	78601	2	COOK BASKET

9-10. Front Ventless Hood



\* Not Shown

# Parts List

# Model: WOG-20MP & WOG-20MP-VH



## 9-10. Parts List for Front Ventless Hood

Item	Part Number	Qty	Description
1	96000	1	FILTER ACCESS COVER
2	45076	1	BAFFLE FILTER, 16 X 16
3	22360	1	E.A.C. FILTER CELL, 16"
4	31963	1	CHARCOAL FILTER, 16 X 12-3/8
5	21125	1	CONTACT BOARD, E.A.C. CELL
6	24237	1	SWITCH, PLUNGER, 250V, 15A (FILTER COVER INTLK)
*7	30206	1	GREASE DRIP CUP (UNDER HOOD)
*8	34750	1	DRIP CUP SAFETY SHACKLE (UNDER HOOD)
9	93312	1	PIN, SWITCH ACTUATOR, FILTER DOOR
*10	41133	1	RETAINING RING, 1/4"

\* Not Shown

9-11. Filter Pan

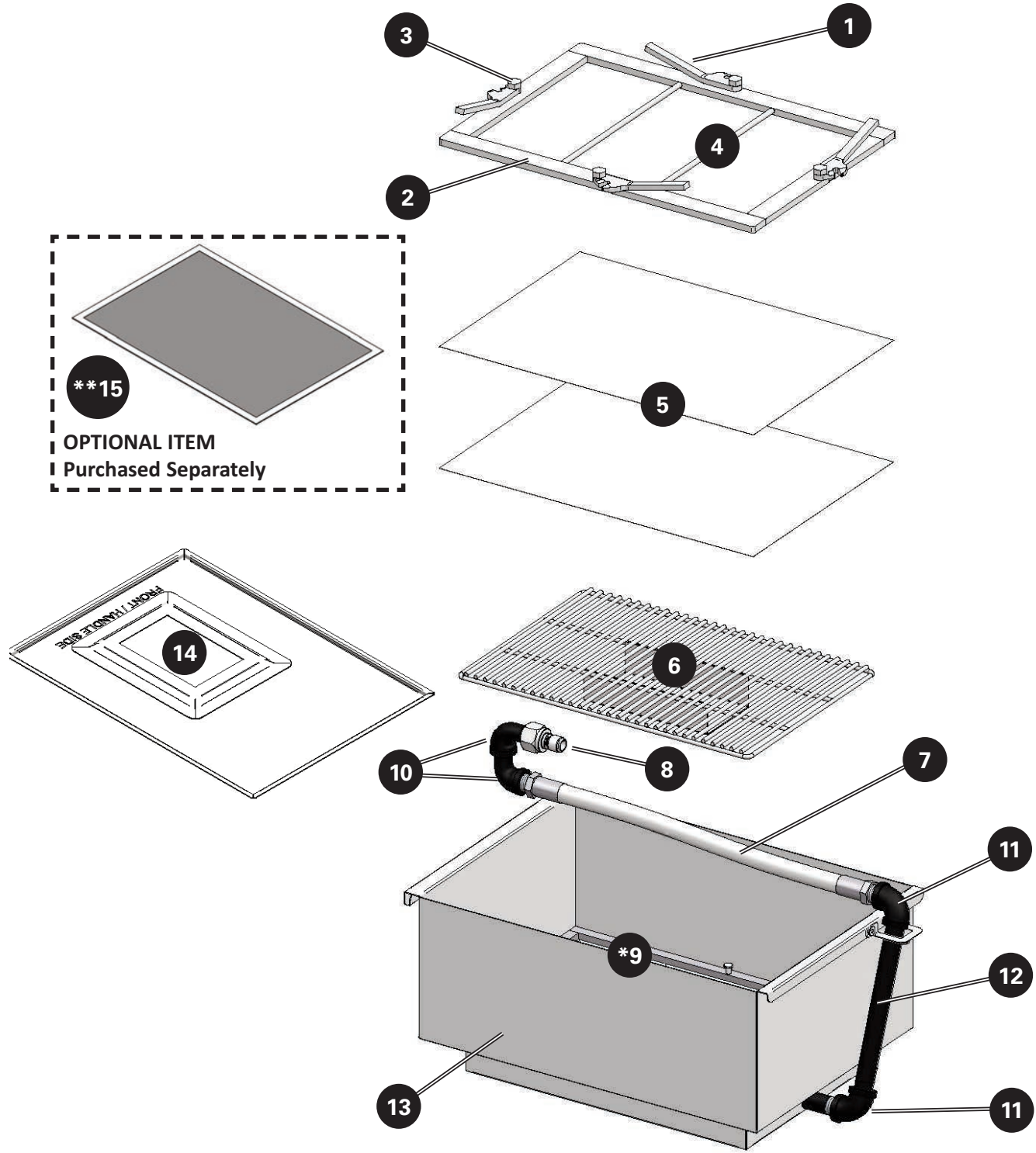

\* Complete Filter Pan Assembly (includes all parts except #14)

# Parts List

# Model: WOG-20MP & WOG-20MP-VH

## 9-11. Parts List for Filter Pan

Item	Part Number	Qty	Description
1	54526	4	LEVER, HOLD-DOWN FRAME
2	30938-4	1	HOLD-DOWN FRAME ( <b>FRAME ONLY</b> )
3	30040-4	4	STUD, HOLD-DOWN FRAME
4	30938	1	HOLD-DOWN FRAME ASSEMBLY, COMPLETE ( <b>INCLS. #1, #2, #3</b> )
5	72002	2	PAPER FILTER MEDIA, 11-1/2 X 16-9/16 ( <b>100-CT CASE</b> )
6	30939	1	SUPPORT SCREEN ASSEMBLY
7	40961	1	HOSE, 1/2 NPT X 21", SWIVEL FITTING 1-END
8	44150	1	FITTING, MALE QUIK-DISCONNECT, 1/2-NPT, STAINLESS
*9	96163	1	COMPLETE FILTER PAN ASSEMBLY ( <b>ALL PARTS</b> )
10	42250	2	STREET ELL, 1/2", 90°, BLACK PIPE
11	42200	2	ELL, 1/2", 90°, BLACK PIPE
12	40403	1	NIPPLE, 1/2" X 8-1/4", BLACK PIPE
13	96155	1	FILTER PAN WELD ASSEMBLY ( <b>PAN ONLY</b> )
14	96695	1	FILTER PAN COVER
**15	41020	1	MICRO-MESH FILTER SCREEN, 11-1/2" X 16-9/16" ( <b>OPTIONAL</b> )

**NOTE:** The optional Micro-Mesh Filter Screen is a direct replacement for paper filter media. It can be cleaned and reused many times.

\* Complete Filter Pan Assembly (includes all parts except #14)

\*\* OPTIONAL ITEM, Purchased Separately



**Notes:**

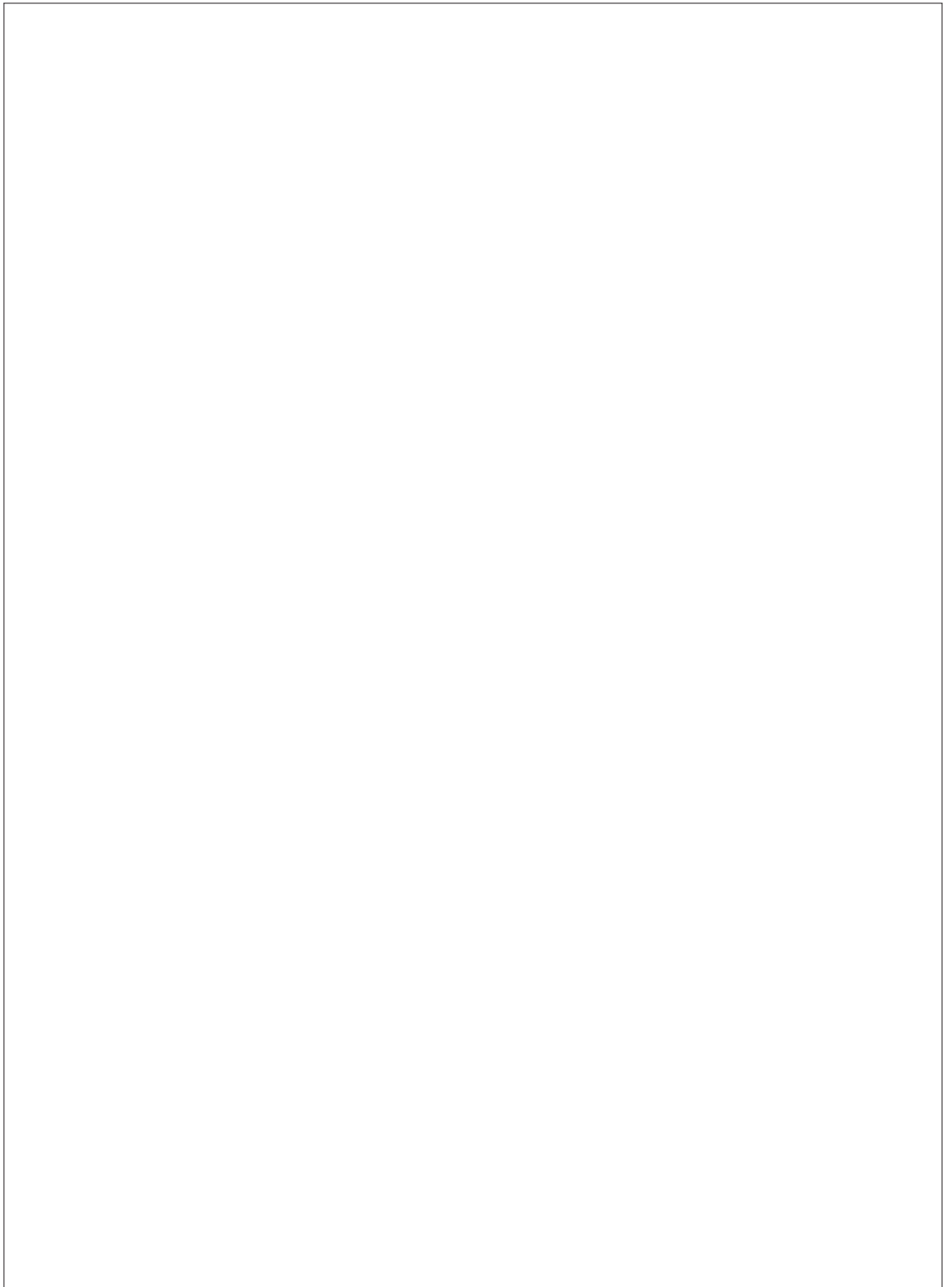



**Giles Enterprises, Inc.**

2750 Gunter Park Drive West • Montgomery, AL 36109 USA  
Phone 334.272.1457 • TOLL FREE 800.554.4537 (USA & Canada Only) • FAX 334.239.4117 • [www.gfse.com](http://www.gfse.com)

Form No. 60199 (Rel. Nov.2000, Rev. E, Nov.2016)