

QUICKGEL FROZEN PRODUCT DISPENSER

Project	Date	Models	QuickGel	Item#	Quantity
---------	------	--------	----------	-------	----------



model QuickGel

Features

- Similar to slush machines, but with a stronger freezing compressor that chills at or below 20° F, creating a product similar to soft serve.
- 1.0 gallon (3.8 L) bowl, with 30 lbs (13.6 kg) per hour production.
- Standby mode available for overnight storage of blends.
- Perfect for coffee shops, casual and high-end restaurants, quick-serve restaurants, bars, gelato shops, frozen yogurt shops, convenience stores, bakeries, and more.
- Simple, user-friendly interface and compact design.
- The modern design of the machine draws customers and drives sales.
- LED back-lit, easy to replace graphics.
- Optional lid locking.

Models & Dimensions

QuickGel Frozen Product Dispenser

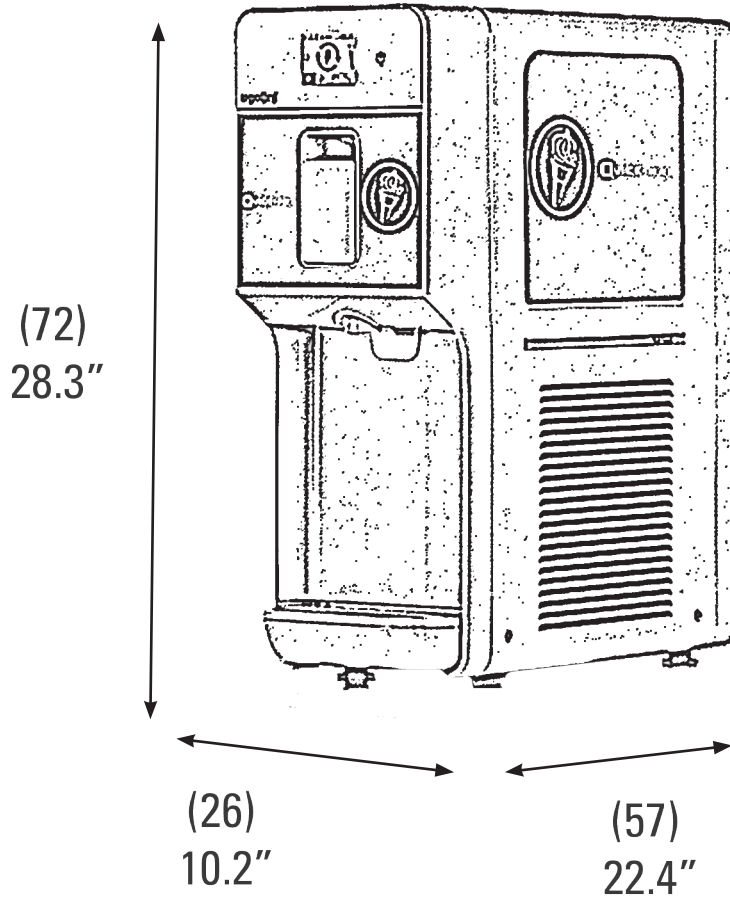

model QuickGel represented measurements in inches [cm]

Specifications

Model	Description	Product Dimensions (H x W X D)	Ship Weight
QuickGel	1.0 gallon (3.8 L) bowl, with 30 lbs (13.6 kg) per hour production.	28.3" x 10.2" x 22.4" (72 x 26 x 57)	121 lbs. (55kg)

