



Project: \_\_\_\_\_  
 Location: \_\_\_\_\_  
 Item #: \_\_\_\_\_ Quantity: \_\_\_\_\_  
 Model #: \_\_\_\_\_

**MODEL: VSU 63 L** **SUSHI CASES – Left Condensing Unit**



VSU 63 L

**General Strengths**

- ✓ **Sanitation.** The interior cabinet is built with rounded corners (extensive radius for easy cleaning). Quick ability to take off shelves and slides for interior cleaning. Each cabinet has a drain at the bottom of the unit. When cleaning the unit make sure the drain hose is routed to a floor drain.
- ✓ **Control systems.** Higher precision in managing temperature settings. Greater ability to adjust temperature ranges as per the end user's requirement.

- ✓ **100% Tested.** All condenser units are tested 100%, in helium chambers to refrigerant leak detections.
- ✓ **Certified.** Audited and Certified by **INTERTEK** for compliance with UL 471 and NSF 7. AENOR audited and certified by internationally recognized firm. ISO 9001:2008 (Quality); ISO 14001:2004 (Environmental); OSHAS 18001:2007 (Prevention and Worker Safety)
- ✓ **Lighting.** Interior cabinet includes LED lighting, for brighter lighting and energy efficiency. LED saves 90% more energy compared to traditional fluorescent bulbs. Increases product visibility considerably.

MODEL	Dimensions (inches) (mm)			Nº Doors	Ref.	Ref. Weight (Lbs.) (gr.)	Temp. Range (°F) (°C)	Capacity (Cu. Ft.) (L)	Cond. Unit. H.P.	Case Amps 115 V.	Crated Weight (Lbs.) (Kg.)
	W	D	H								
VSU 63 L	63-3/4	16-1/8	9	2	R134a	0.83	30°F/34°F	.84	1/8	3.4	132
	1620	410	230								

ETL LISTED TO UL471 STANDARD AND SANITATION CLASSIFIED TO NSF7 – WE RESERVE THE RIGHT TO CHANGE SPECIFICATIONS WITHOUT PRIOR NOTICE



**Infrico USA Corp.**  
 3325 N.W. 70th Avenue  
 Miami, FL 33122-1332  
 1.305.777.9599 Office  
 1.305.777.9598 Fax

[www.infrico.us](http://www.infrico.us)  
 operations@infrico.com  
 service@infrico.com  
 sales@infrico.com

**APPROVALS: AVAILABLE AT:**

Revision: 01 Date: 10/10/2013



Project: \_\_\_\_\_

Location: \_\_\_\_\_

Item #: \_\_\_\_\_ Quantity: \_\_\_\_\_

Model #: \_\_\_\_\_

**MODEL: VSU 63 L** **SUSHI CASES – Left Condensing Unit**

**STANDARD FEATURES**

➤ **Exterior**

- AISI 304 Stainless Steel,
- Front lift-up glass system,
- Levelling feet.



➤ **Interior**

- AISI 304 Stainless Steel,
- Internal drain plug for high water pressure cleaning,
- Sealed interior floors and rounded cabinet corners.
- LED Lighting in top profile.

➤ **Insulation**

- High density CFC free Polyurethane foam.

➤ **Doors**

- Rear sliding windows included.

➤ **Refrigeration**

- Temperature regulated by a digital controller.
- Ventilated condensation system.
- Cooling plate and gravity coil.

➤ **Electrical**

- Cord and NEMA 5-15P plug. 
- Electrical connection is 115V / 1ph / 60 Hz.

➤ **ETL Listed to UL471 Standard and Sanitation classified to NSF7.**



Only exposure previously refrigerated product  
Remove the product and disconnect daily

**OPTIONAL FEATURES**

- ✓ Electrical connection is 220-230 V / 1ph / 50 Hz (plug type varies).

**PLAN VIEW**

**RIGHT VIEW**

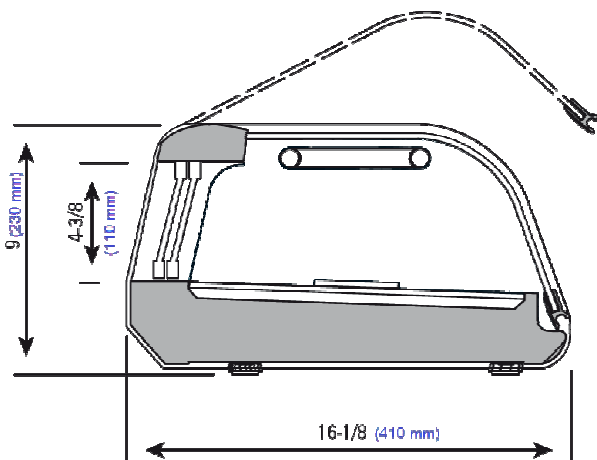

**ELEVATION**

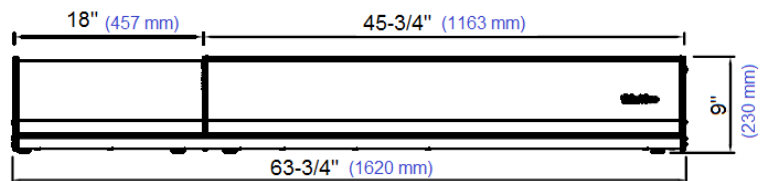

**PLAN VIEW**

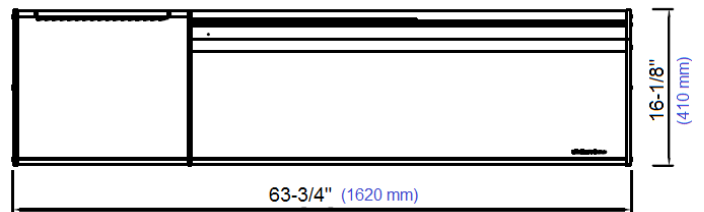

Revision: 01 Date: 10/10/2013

ETL LISTED TO UL471 STANDARD AND SANITATION CLASSIFIED TO NSF7 – WE RESERVE THE RIGHT TO CHANGE SPECIFICATIONS WITHOUT PRIOR NOTICE



**Infrico USA Corp.**  
3325 N.W. 70th Avenue  
Miami, FL 33122-1332  
1.305.777.9599 Office  
1.305.777.9598 Fax

**www.infrico.us**  
operations@infrico.com  
service@infrico.com  
sales@infrico.com

**APPROVALS: AVAILABLE AT:**