

# SELF-CONTAINED KETTLE

ELECTRIC, INSULATED  
TILTING, FLOOR MOUNTED  
DEEP DRAWN CONSTRUCTION  
MADE IN USA

# MODEL TEH-F

## STANDARD FEATURES



**Model TEH-10F**  
with optional lift-off cover

- ◆ 316 stainless liner
- ◆ 304 stainless kettle jacket
- ◆ Kettle protection system
  - ◇ 50 psi safety valve and maximum operating pressure
  - ◇ Pressure gauge
  - ◇ Jacket-water fill
  - ◇ Thermostat temperature control
  - ◇ Automatic low water cut off and indicator light
  - ◇ Field replaceable heating elements
  - ◇ Tilting cut-off switch
- ◆ Full body insulation between kettle jacket and outer casing
- ◆ 304 stainless outer casing seam welded to radius lip
- ◆ 304 stainless, seam welded control console with water resistant cover
- ◆ 304 stainless, 2" tubular support frame
- ◆ 304 stainless, coved corner sliding drawer
- ◆ 304 stainless, pitched drain trough with 1 1/2" drain
- ◆ Adjustable flanged feet

Legion equipment is built to comply with applicable standards for manufacturers. Approval agencies may include ASME, NSF, UL, ETL, AGA, CSA, CGA, and others. Legion reserves the right of design improvement or modification as warranted.

MODELS AND CAPACITIES			OPTIONAL FEATURES AND ACCESSORIES	
			See price list for supplemental information regarding options	
TEH-5F	5 gal.	(19 l.)	<input type="checkbox"/> Single or double fill faucet with bracket & 12 or 18" swing nozzle <input type="checkbox"/> 48" flexible spray hose assembly (vinyl or stainless) for use with dual or single fill faucet <input type="checkbox"/> Faucet bracket <input type="checkbox"/> Automatic water filling meter <i>(Call for information regarding additional faucet options)</i> <input type="checkbox"/> Single basket insert <input type="checkbox"/> Nylon bag insert with spreader ring <input type="checkbox"/> Lift-off cover <input type="checkbox"/> Pressure switch	<input type="checkbox"/> Anti-splash screen for sliding drawer <input type="checkbox"/> Mixer/Agitator, single speed  <b>Prison/Security Options:</b> <input type="checkbox"/> Fasteners ( <i>screws &amp; nuts</i> ) <input type="checkbox"/> Nut driver tool <input type="checkbox"/> Screw driver tool <input type="checkbox"/> Lockable control cover
TEH-10F	10 gal.	(38 l.)		
Select voltage: <input type="checkbox"/> 208V <input type="checkbox"/> 240V <input type="checkbox"/> 380V <input type="checkbox"/> 415V <input type="checkbox"/> 440V <input type="checkbox"/> 480V Select phase: <input type="checkbox"/> 1Ø <input type="checkbox"/> 3Ø				

Revision 999



**LEGION**® The Finest American Quality Since 1897

LEGION INDUSTRIES, INC. ◆ 69 MAIN ST. ◆ DALLAS, PA 18612 ◆ (800) 833-9803 ◆ (570) 675-1575 ◆ FAX: (570) 675-7551

**MODEL  
TEH-F**

**ELECTRIC, INSULATED  
TILTING, FLOOR MOUNTED  
DEEP DRAWN CONSTRUCTION  
MADE IN USA**

**SELF-CONTAINED  
KETTLE**

DRAWING REPRESENTS MODEL TEH-5F

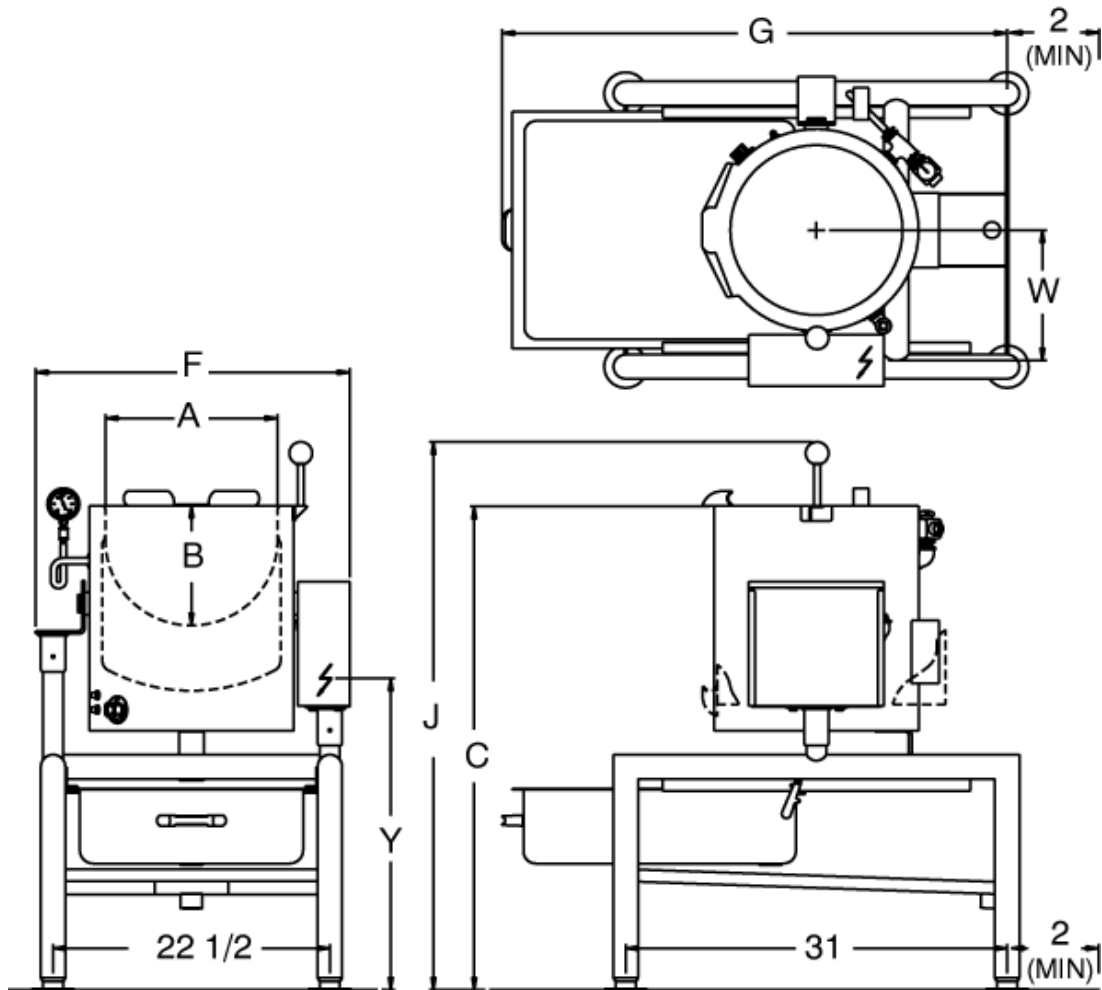

MODEL TEH-F DIMENSIONS								
GAL.	A	B	C	F	G	J	W	Y
5	14.0	9.9	40.0	25.5	41.5	45.3	10.8	25.0
10	16.0	14.0	44.0	27.5	44.0	49.3	11.8	27.0

MODEL TEH-F ELECTRICAL SPECIFICATIONS													
<i>(Table represents amperes per phase)</i>													
GAL.	KW	208 VOLT		240 VOLT		380 VOLT		415 VOLT		440 VOLT		480 VOLT	
		1Ø	3Ø	1Ø	3Ø	1Ø	3Ø	1Ø	3Ø	1Ø	3Ø	1Ø	3Ø
5	6.0	21.7	12.5	25.0	14.4	15.8	9.1	14.5	8.3	11.5	6.6	12.5	7.2
10	12.0	43.3	25.0	50.0	28.9	31.6	18.2	28.9	16.7	22.9	13.2	25.0	14.4

Revision 999



**LEGION**

*The Finest American Quality Since 1897*

LEGION INDUSTRIES, INC. ♦ 69 MAIN ST. ♦ DALLAS, PA 18612 ♦ (800) 833-9803 ♦ (570) 675-1575 ♦ FAX: (570) 675-7551