

Job: \_\_\_\_\_

Item No: \_\_\_\_\_

## CA31-PF10-CD-R

### Economy Proofer - Non Insulated

#### Features:

- Digital thermometer
- Temperature adjustable to approximately 160° F
- Exterior mounted controls
- Easy to use heat unit with separate temperature and humidity controls
- Removable heat unit for easy maintenance and repair
- Blower fan and pan stop provide uniform heat distribution throughout cabinet
- 18" x 26" pans are lip-hung on 1 1/2" centers
- Standard with right hand hinging; left hand hinging available upon request



#### Options:

- Solid aluminum door
- Perimeter or corner bumpers
- Hasp lock
- Caster options available



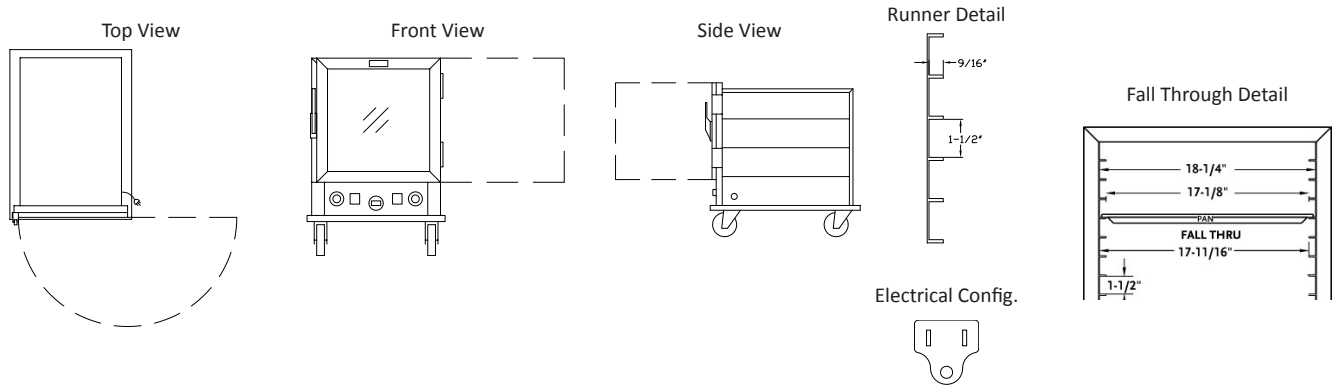

| Lockwood Model No. | Pan            |          |    | Exterior Dimensions |         |        | Inside Dimensions |        |        |     | Weight |
|--------------------|----------------|----------|----|---------------------|---------|--------|-------------------|--------|--------|-----|--------|
|                    | Angles         | Capacity |    | Width               | Depth   | Height | Width             | Depth  | Height |     |        |
| CA31-PF10-CD-R     | Extruded Sides | 10       | IN | 22 3/8              | 31 3/16 | 31 7/8 | 18 1/4            | 26 3/4 | 17 3/4 | LBS | 63     |
|                    |                |          | CM | 56.85               | 79.22   | 80.98  | 46.36             | 67.95  | 44.09  | KG  | 28.57  |

\*\* Add 2" to width and depth with corner bumper option

**Cabinet Specifications:**

- Top & back panel: One piece 0.125" aluminum welded to extruded side panels and base
- Side panels: Extruded .070" aluminum panels; welded together.

**Base Specifications:**

- One piece .125" aluminum; formed construction
- Casters: (4) 5" x 1 1/4" High Tech grey swivel (2 w/brakes); load capacity 250 lbs each (113.4 kg); temp. range -45 ° / +180° F

**Door Specifications:**

- Frame: 7/8" x 1 3/4" extruded aluminum screwed and welded together
- Panel: .118" clear polycarbonate, fitted into door frame
- Latch: Magnetic type latch handle screwed to door frame
- Hinges: 4" stainless steel - opens 180°
- Gasket: Perimeter; fitted into frame extrusion, flexible PVC rubber

**Pan Support Specifications:**

- Extruded .070" aluminum

**Heat Unit Specifications:**

- Removable bottom mount proof / hold unit
- Body: Formed .063" aluminum
- Thermostat (holding): Mechanical, up to 195°
- Thermostat (humidity): Mechanical, up to 95%
- Indicator lights: Power, Proof, Hold modes
- Switches: (2) Rocker type with guards
- Heat Elements: (1) 1000 W, (1) 500 W internal; (1) 1000 W immersible external for proofing
- Blower Motor
- Thermometer
- Water Pan: 4.3 quart, 23 ga., 18/8 stainless steel

**Power Requirements:**

- 1500 Watts, 120 Volts, 60 Hz, Single Phase 15 Amp.
- Dedicated 15 Amp. service.

***Lockwood reserves the right to change materials and specifications without notice.***