

JET-TECH

model X-33

Low-temp undercounter dishwasher

**X-33 CLEANS YOUR DISHES, GLASSWARE, SILVERWARE AND UTENSILS.
THIS MODEL IS EXCELLENT FOR SMALL RESTAURANTS, FAST FOOD OPERATIONS,
INSTITUTIONS, NURSING HOMES, ETC.**



- Fully automatic washing and rinsing operation with integrated chemical injection system
- Wash tank heater to ensure and maintain proper temperature
- Sanitary labyrinth door eliminates any gasket
- Deep drawn one piece unified inner chamber
- Rinse-additive pump for sparkling results
- Detergent pump for consistent results
- Chemical sanitizing pump
- Just the push of one button fills the wash tank
- No need for any booster heater
- New and improved wash arm design
- Highest quality fabrication using the most advanced machinery will ensure long-life and increased durability
- Slide out control panel for ease of service & maintenance
- Automatic drain valve mechanism assists to drain water up to a height of 36"
- Stainless steel wash and rinse arms
- Inner wash tank stamped in AISI 316 — resists corrosion

model X-33

Low-temp undercounter dishwasher



CONTROL PANEL

Slide out control panel provides quick access to all essential electrical components.



3 PERISTALTIC PUMPS

The X-33 comes equipped with three peristaltic pumps with prime switches.



BAND HEATER

Helps maintain wash water at the proper temperature.



INNER WASH TANK

Stainless steel wash/rinse arms.

STANDARD FEATURES

- Stainless steel pump impeller provides greater durability
- Standard insulated top and side panels
- Stainless steel upper and lower wash/rinse arms are interchangeable and easily removed for cleaning
- Body, external housing and all chasis components in brushed stainless steel AISI 304
- 0.75 HP drip-proof pump motor
- Door safety switch
- Adjustable peristaltic pumps for detergent, rinse and sanitizer
- Door opening height of 15 inches
- Reliable mechanical type cam timer
- Detergent/chemical connections
- Delime switch
- Cycle counter
- **Standard equipment includes:** One open combination rack and one peg dish rack 19.75" x 19.75" (500 mm x 500 mm)

TECHNICAL FEATURES

- **Racks per hour:** 37
- **Water consumption per cycle (Gal.):** 1.00
- **Wash Motor:** 0.75 HP
- **Wash Time:** 45 seconds
- **Dwell Time:** 12 seconds
- **Rinse Time:** 28 seconds
- **Total cycle time:** 85 seconds
- **Shipping weight:** 178 lbs. (81 kg.)

OPTIONAL ACCESSORIES

- Pressure reducing valve (PRV) kit

UTILITIES

Electrical: 115/60/1 13 Amps. Cord and plug included

Water Supply: 1/2" hot water supply 140°F/60°C

Flow Pressure: 25 p.s.i. (dynamic) (PRV may be required)

Water Inlet Connection: 3/4" male hose connector (hose included)

Drain Connection: 1" ID (25.4mm) Max. height 36"/915mm (hose included)



ANSI/NSF-3

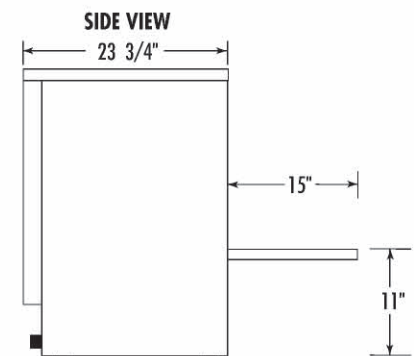
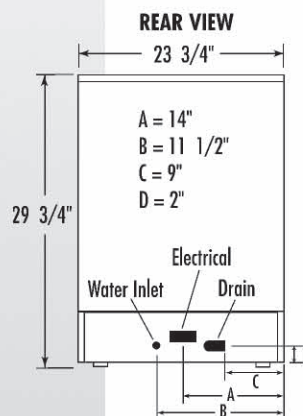
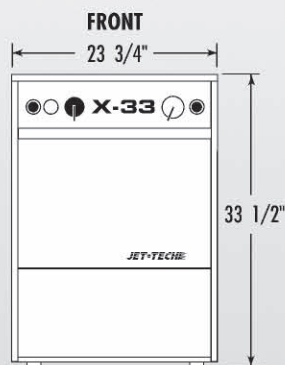

MVP GROUP CORPORATION

HEAD OFFICE: 5659 Royalmount Ave., Montreal, QC, Canada H4P 2P9

TEL: (514) 737-9701 • TOLL FREE: (888) 275-4538 • FAX: (514) 342-3854 • TOLL FREE FAX: (877) 453-8832

www.mvpgroupcorp.com • e-mail: sales@mvpgroupcorp.com

In line with our continuing policy on research and product development, we reserve the right to alter specifications and prices without notice.