



TC 32 CALIFORNIA

tritacarne meat grinders



- Tritacarne solido, robusto e performante adatto a piccoli laboratori, collettività, mense e grandi cucine.
- Dotato di gambe e ruote in acciaio inox con freno per una sicura stabilità e grande praticità
- Maneggevole, comodo e compatto lo rendono adatto ad ogni tipologia di spazio
- Corpo macchina totalmente in acciaio inox AISI 304.
- Grande tramoggia di carico cm 410x610x76 mm con micro per una maggior sicurezza
- Potenti motori IP 55 autoventilati per uso continuo.
- Riduttore a bagno d'olio con ingranaggi rettificati.
- Riduttore con doppio sistema di protezione dai liquidi.
- Rapido fissaggio bocca senza utensili.
- Gruppo macinazione completamente in acciaio inox facilmente e totalmente smontabile per pulizia.
- Tramoggia rimovibile interbloccata (CE).
- Comandi inox, 24 Volt IP67.

Opzioni:

- Sistema di protezione interbloccato per uso piastre con foro > 8 mm.
- Bocche Unger parziale o totale.

- Heavy-duty meat grinder with high capacity, suitable for all kitchens;
- The machine is on stand with stainless steel casters and therefore very stable and easy to move;
- AISI 304 stainless steel construction;
- large 410x610x76 mm feeding tray with safety microswitch;
- Powerful IP55 insulated and cooled motors for continuous use;
- Endless screw motor-reducer an oil-bath enables a long service life .
- Reducer equipped with a double seal for long, trouble-free service.
- Head can be locked in with no tools.
- Stainless steel head with high output capacity, completely removable for cleaning.
- Feed tray provided with safety interlock CE versions.
- Stainless steel IP 67 protected, 24 V controls.

Optional:

- Interlock protection for more than 8 mm holes plates (An interlock protection system is required in order to utilize more than 8 mm holes plates).
- Partial or total Unger mincing head.

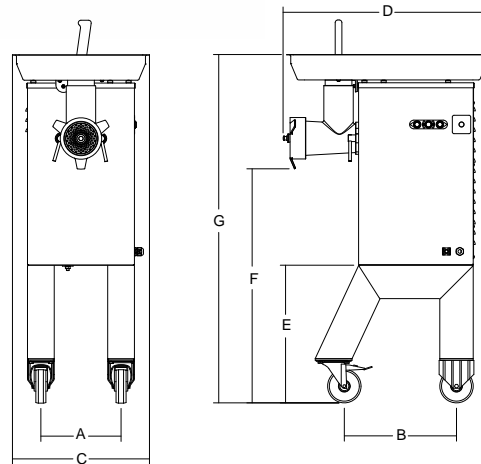

Standard o enterprise 1/2 Unger Unger Totale

	Potenza Power Spannung Puissance	Alimentazione Power source Betriebsspannung Alimentation	Prod. oraria TC TC Output/h. TC Leistung/h. TC Débit/h.	Placina indolazione Standard Plate Scheibe Filieres	A	B	C	D	E	F	G	Peso netto Net weight Nettogewicht Poids net	Dimensioni imballo Shipping Verpack. abmessungen Dim. emballage	Peso lordo Gross weight Bruttogewicht Poids brut
	watt/Hp		Kg/h.	ø mm	mm	mm	mm	mm	mm	mm	mm	Kg	mm	kg
TC 32 California	2205/3	230-400V/50Hz	400	6	240	336	410	621	412	700	1042	55	720x570x1180	70

Potencia Potência Мощность	Alimentación Alimentação Электропитание	Producción/h. TC TC produção/h. Производство TC TC产量/小时	Placa en indolación Lamina en indolado Решетка 榨配刀盘	A	B	C	D	E	F	G	Peso netto Peso líquido Вес нетто	Dimensiones embalaje Dimensões embalagem Размеры упаковки	Peso bruto Peso bruto Вес брутто
功率	电源	TC产量/小时	榨配刀盘	mm	mm	mm	mm	mm	mm	mm	净重	包装尺寸	毛重