



SIRIO

frappè drink mixers



- Famiglia completa di macchine per il frappè caratterizzato da linee morbide e precise. Studiato per un utilizzo professionale e severo nel rispetto delle norme di sicurezza europee e nordamericane.
- Corpo macchina bianco o cromato, colonna in alluminio estruso e base in pressofusione per una ottima stabilità della macchina, il tutto privo di angoli e giunzioni per facilitare la pulizia.
- Disponibile nella versione da banco 1 o 2 bicchieri o a parete.
- Bicchiere da 550 cc in Tritan trasparente o a richiesta in acciaio inox.
- Bicchiere da 900 cc in acciaio inox su versione da 120 watt.
- Motore potente e ventilato per una maggiore durata.
- Versione con 3 fruste in alluminio e acciaio per la preparazione di frappè e sorbetti o con disco appositamente studiato per il caffè shakerato o per montare il prodotto in lavorazione.
- Microinterruttore di sicurezza sul bicchiere (opzionale per paesi extra UE).
- Variatore di velocità a richiesta.

- *A complete line of drink mixers with a soft design.*
- *Designed to commercial use, they meet all European and North-American safety requirements.*
- *White or chrome head, aluminium stem and die casting base for a perfect stability, no edges or seams for easier cleaning.*
- *Countertop (1 or 2 cups) or wall unit versions available.*
- *Transparent 550 cc Tritan cup or stainless steel cup on request.*
- *900 cc stainless steel cup on 120 W version.*
- *Powerful ventilated motor for a longer life.*
- *Spindle with three aluminium and s/steel agitators for preparing milkshakes and drinks, or with a special round agitator for frozen coffees or for creamier results.*
- *Safety microswitch on the cup support (optional for non UE countries).*
- *Speed control on request.*



SIRIO 120W 900 CC



SIRIO GRIGIO



SIRIO 2 VV



SIRIO 2



SIRIO CAFFÈ



1. Particolare fruste, Sirio 120 watt - 900cc
Sirio 120 - 900 watts agitators



2. Opzionale: Anello portabicchieri usa e getta
Optional: ring for paper cups

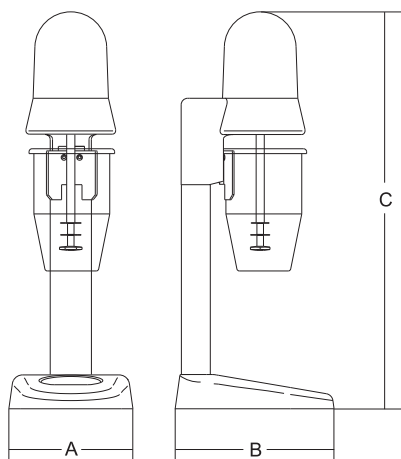

	Potenza Power Spannung Puissance	Alimentazione Power source Betriebsspannung Alimentation	Motore Motor Moteur	Capacità bicchiere Jug capacity Kapazität Capacité verre	A	B	C	Peso netto Net weight Nettogewicht Poids net	Dimensioni imballo Shipping Verpack. abmessungen Dim. emballage	Peso lordo Gross weight Bruttogewicht Poids brut
	watt/Hp		r.p.m.	lit	mm	mm	mm	Kg	mm	kg
Sirio 1	100/0,14	230V 50/60 Hz F+N	14000	0,55	150	195	485	2,5	210x250x520	3,5
Sirio 2	100+100/0,14+0,14	230V 50/60 Hz F+N	14000	0,55x2	300	195	485	5	370x260x530	6,5
Sirio 1P	100/0,14	230V 50/60 Hz F+N	14000	0,55	110	150	360	2	190x240x510	4
Sirio 1 VV	100/0,14	230V 50/60 Hz F+N	4000÷14000	0,55	150	195	485	2,5	210x250x520	3,5
Sirio 2 VV	100+100/0,14+0,14	230V 50/60 Hz F+N	4000÷14000	0,55x2	300	195	485	5	370x260x530	6,5
Sirio Grigio	100/0,14	230V 50/60 Hz F+N	14000	0,55	150	195	485	2,5	210x250x520	3,5
Sirio 1 - 120W cc 900	120/0,16	230V 50/60 Hz F+N	14000	0,9	150	195	530	3	210x250x560	4,5
Sirio 1 VV - 120W cc 900	120/0,16	230V 50/60 Hz F+N	4000÷14000	0,9	150	195	530	3	210x250x560	4,5
Sirio 2 - 120W cc 900	120+120/0,16+0,16	230V 50/60 Hz F+N	14000	0,9x2	300	195	530	6	360x250x560	7
Sirio 2 VV - 120W cc 900	120+120/0,16+0,16	230V 50/60 Hz F+N	4000÷14000	0,9x2	300	195	530	6	360x250x560	7



SIRIO 1 / SIRIO 1 VV



SIRIO 1P VV



SIRIO 1P