

Instructions, Airpot Rack Assembly

Wire airpot racks are easy to assemble. These racks are available in two and three airpot widths. Racks can be combined to lock together and can be configured as two, three, four, five or six airpot groups. Two-wide airpot racks are shown throughout these instructions; the three-wide assembly is identical except for Attaching Legs, page 2.

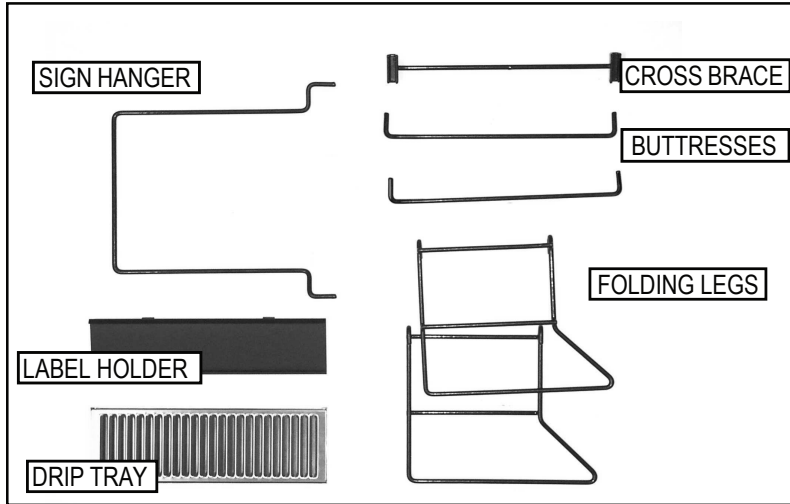

PARTS INCLUDED:



Securing the Back

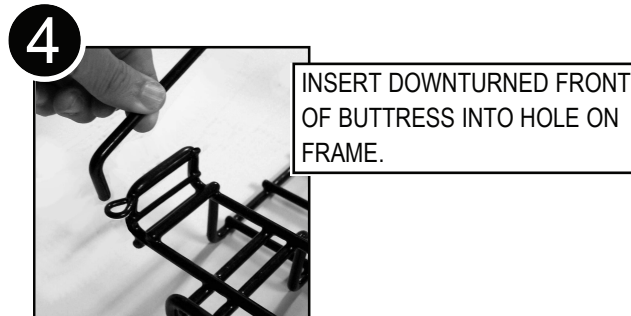
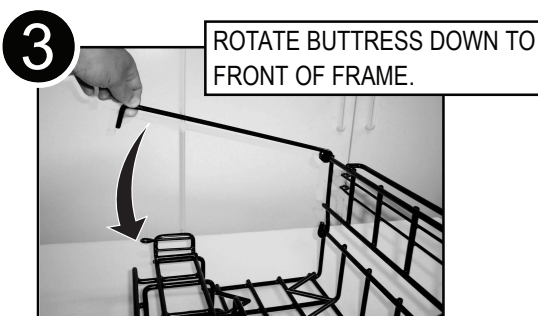
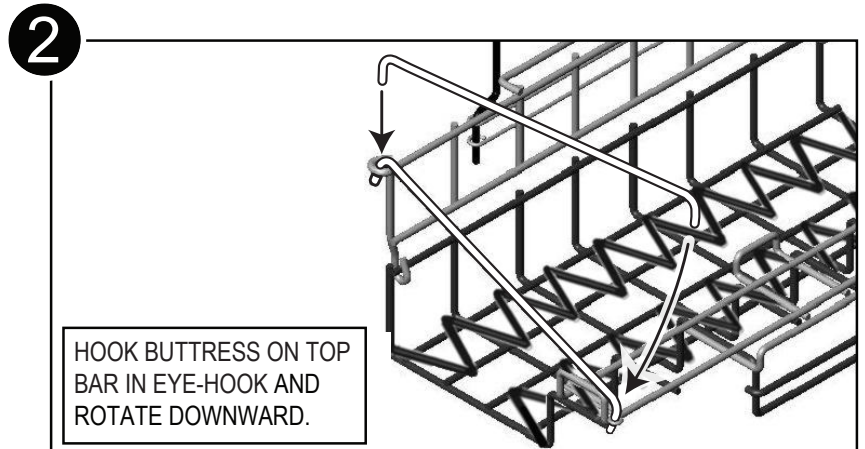
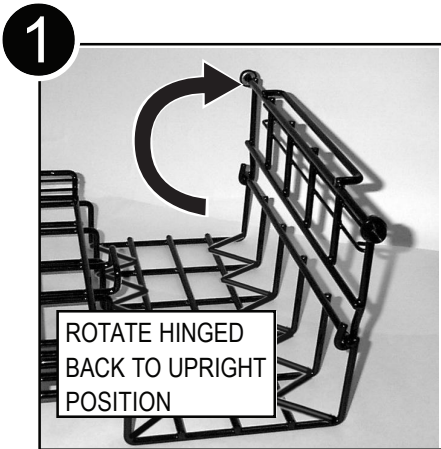

Note: At this point, airpot rack may be used as a single level group of airpots of two or three across.

CONTINUED . . . OVER



WILBUR CURTIS CO., INC.
6913 Acco St., Montebello, CA 90640-5403 USA
Phone: 800/421-6150 ♦ Fax: 323-837-2410
♦ Technical Support Phone: 800/995-0417 (M-F 5:30A - 4:00P PST) ♦ E-Mail: techsupport@wilburcurtis.com
♦ Web Site: www.wilburcurtis.com

FOR THE LATEST SPECIFICATION INFORMATION GO TO WWW.WILBURCURTIS.COM

Attaching the Legs

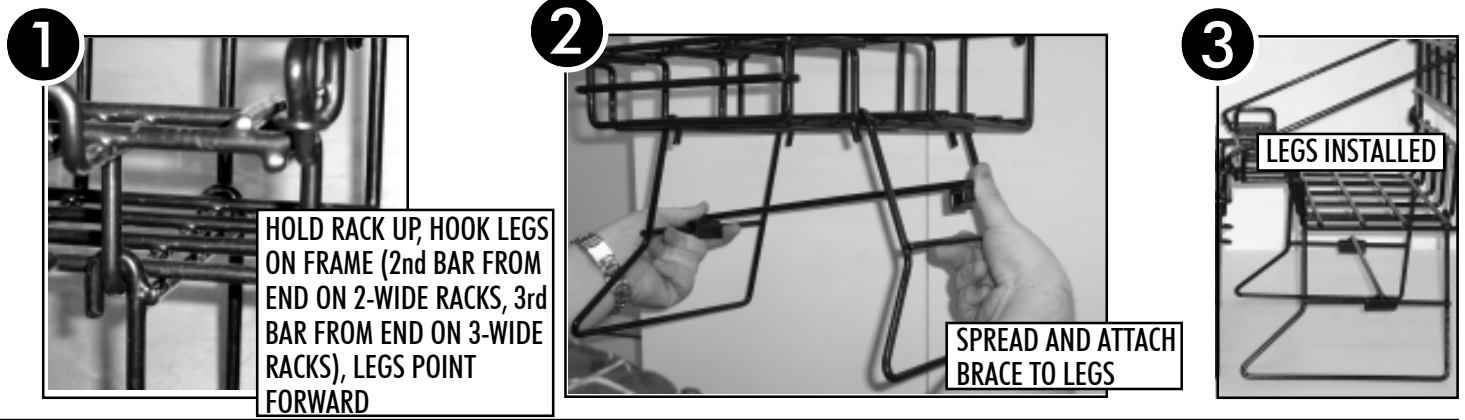

Attaching the Sign Hanger

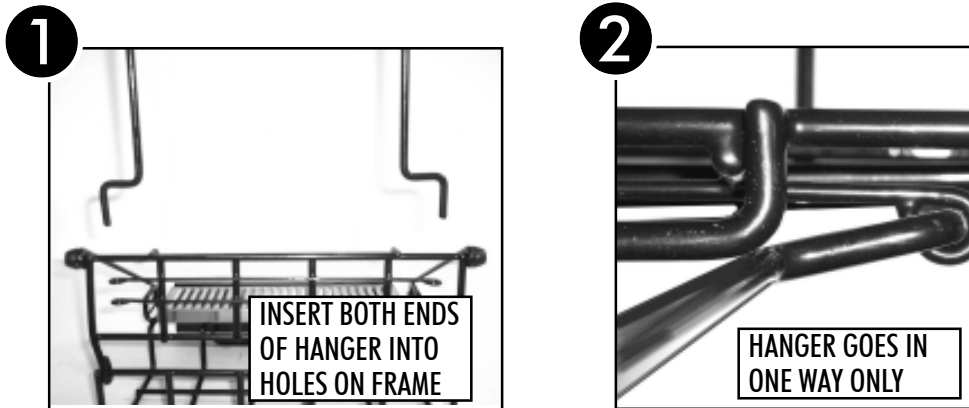

Place Drip Tray



Hooking Racks Together

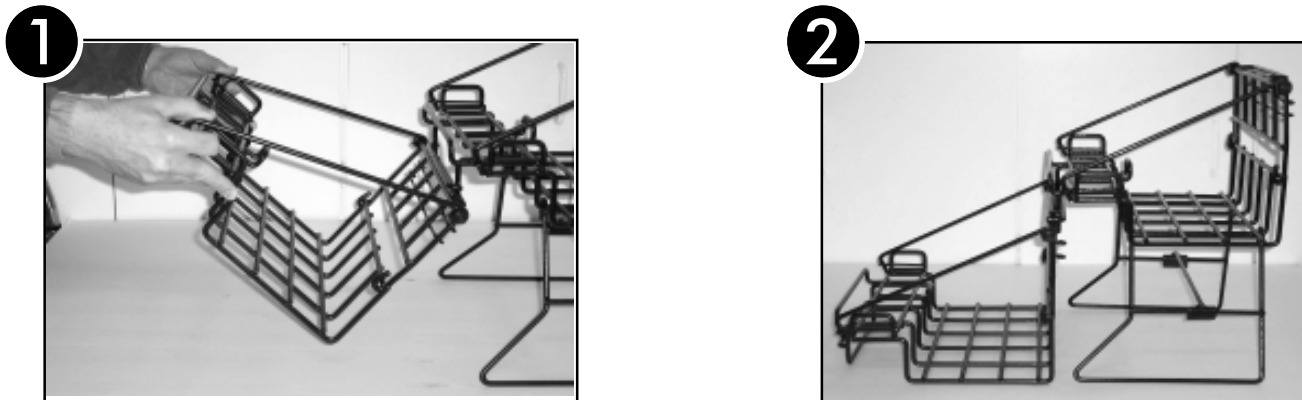

Attaching Label Holders

Label holders can be attached to the airpot rack in two places:



On the tall sign hanger that inserts into the back side of the airpot rack.

On the front of the rack.

